

Contents		Page
Safety Precautions and Warnings		5
1. OVERVIEW		7
1.1	Description and Features	7
1.2	Options	9
1.3	MICRO MASTER and MIDI MASTER Variants	9
2. INSTALLATION		10
2.1	Wiring Guidelines to Minimise the Effects of EMI	10
2.2	Mechanical Installation	11
2.3	Electrical Installation – MICRO MASTER	12
2.3.1	Power and Motor Connections	13
2.3.2	Control Connections	14
2.4	Electrical Installation – MIDI MASTER	15
2.4.1	Power and Motor Connections	17
2.4.2	Control Connections	18
3. FRONT PANEL CONTROLS		19
4. OPERATING INFORMATION		21
4.1	General	21
4.2	Basic Operation	21
4.3	Operation – Digital Control	22
4.4	Operation – Analogue Control	22
4.5	Stopping the Motor	22
4.6	If the Motor Does Not Start Up	23
4.7	Local and Remote Control	23
5. SYSTEM PARAMETERS		24
6. FAULT CODES		34
7. SPECIFICATIONS AND SUPPLEMENTARY INFORMATION		35
7.1	Specifications	35
7.2	Options / Accessories	37
7.3	Application Example	38
7.4	Technical Terms	38
7.5	Parameter Summary List	39

Figures

1	MICRO MASTER / MIDI MASTER Block Diagram	8
2	Mechanical Installation Diagram – MICRO MASTER	11
3	Mechanical Installation Diagram – MIDI MASTER	11
4	The MICRO MASTER – Internal Layout	12
5	Mains Input / Motor Terminal Connections – MICRO MASTER	14
6	Control Connections – MICRO MASTER	14
7	The MIDI MASTER – Internal Layout	16
8	Mains Input / Motor Terminal Connections – MIDI MASTER	17
9	Control Connections – MIDI MASTER	18
10	Front Panel	19
11	Procedure for Changing Parameter Values	20
12	Motor Rating Plate Example	21

This page is intentionally blank

Safety Precautions and Warnings

Before installing and putting this equipment into operation, please read these safety precautions and warnings carefully and all the warning signs attached to the equipment. Make sure that the warning signs are kept in a legible condition and replace missing or damaged signs.



WARNING

This equipment contains hazardous voltages and controls hazardous rotating mechanical parts. Loss of life, severe personal injury or property damage can result if the instructions contained in this manual are not followed.

Only suitable qualified personnel should work on this equipment, and only after becoming familiar with all safety notices, installation, operation and maintenance procedures contained in this manual. The successful and safe operation of this equipment is dependent upon its proper handling, installation, operation and maintenance.

- The MICRO MASTER and MIDI MASTER operate at high voltages.
- The dc-link capacitor remains charged to dangerous voltages even when the power is removed. For this reason it is not permissible to open the equipment until five minutes after the power has been turned off. When handling the open equipment it should be noted that live parts are exposed. Do not touch these live parts.
- Machines with a three phase power supply must not be connected to a supply via an ELCB (Earth Leakage Circuit-Breaker – see DIN VDE 0160, section 6.5).
- The following terminals can carry dangerous voltages even if the inverter is inoperative:
 - the power supply terminals L/L2, N/L3 or L1, L/L2, N/L3.
 - the motor terminals W, V, U.
 - the braking resistor / braking unit terminals B+, B–.
- Only qualified personnel may connect, start the system up and repair faults. These personnel must be thoroughly acquainted with all the warnings and operating procedures contained in this manual.
- Certain parameter settings may cause the inverter to restart automatically after an input power failure.



CAUTION

- Children and the general public must be prevented from accessing or approaching the equipment!
- This equipment may only be used for the purpose specified by the manufacturer. Unauthorised modifications and the use of spare parts and accessories that are not sold or recommended by the manufacturer of the equipment can cause fires, electric shocks and injuries.
- Keep these operating instructions within easy reach and give them to all users!

Definitions

- **Qualified Person**

For the purposes of this manual and product labels, a qualified person is one who is familiar with the installation, construction, operation and maintenance of this equipment and with the hazards involved. In addition, the person must be:

- (1) Trained and authorised to energise, de-energise, clear, ground and tag circuits and equipment in accordance with established safety practices.
- (2) Trained in the proper care and use of protective equipment in accordance with established safety practices.
- (3) Trained in rendering first aid.

- **DANGER**

For the purposes of this manual and product labels, DANGER indicates that loss of life, severe personal injury or substantial property damage WILL result if proper precautions are not taken.

- **WARNING**

For the purposes of this manual and product labels, WARNING indicates that loss of life, severe personal injury or substantial property damage CAN result if proper precautions are not taken.

- **CAUTION**

For the purposes of this manual and product labels, CAUTION indicates that minor personal injury or property damage CAN result if proper precautions are not taken.

- **Note**

For the purposes of this manual and product labels, Notes merely call attention to information that is especially significant in understanding and operating the inverter.

1. OVERVIEW

1.1 Description and Features

The MICRO MASTER and MIDI MASTER are a range of inverters with a voltage dc-link circuit for variable speed AC drives (see Figure 1). Various options are available, ranging from the compact 250 W MICRO MASTER up to the 37 kW MIDI MASTER (see section 1.3 below).

Both types of inverter are microprocessor-controlled. A special pulse-width modulation method with selectable pulse frequency permits extremely quiet motor operation. Complete inverter and motor protection is provided by various protective functions.

Features

- Microprocessor-control for reliability and flexibility.
- Remote control capability via RS485 serial link using the USS protocol.
- Ability to control up to 31 inverters via the USS protocol.
- A comprehensive range of parameters is provided to enable the inverters to be configured for use in almost any application.
- Built-in non-volatile memory for storing parameter settings.
- Factory default parameter settings pre-programmed for European and North American requirements.
- Output frequency (and hence motor speed) can be controlled by one of five methods:
 - (1) Digital frequency setpoint
 - (2) Analogue setpoint (voltage or current input)
 - (3) Motor potentiometer
 - (4) Fixed frequency
 - (5) Via remote data transmission
- Built-in dc injection brake.
- Built-in brake chopper for external resistor (MICRO MASTER), optional for MIDI MASTER.
- Automatic load compensation by flux current control.
- Built-in ramp generator for variable ramping times.
- Membrane-type front panel controls.
- Two relay outputs incorporated.
- Analogue output incorporated.
- External connection for optional enhanced operator panel or for use as external RS485 interface.

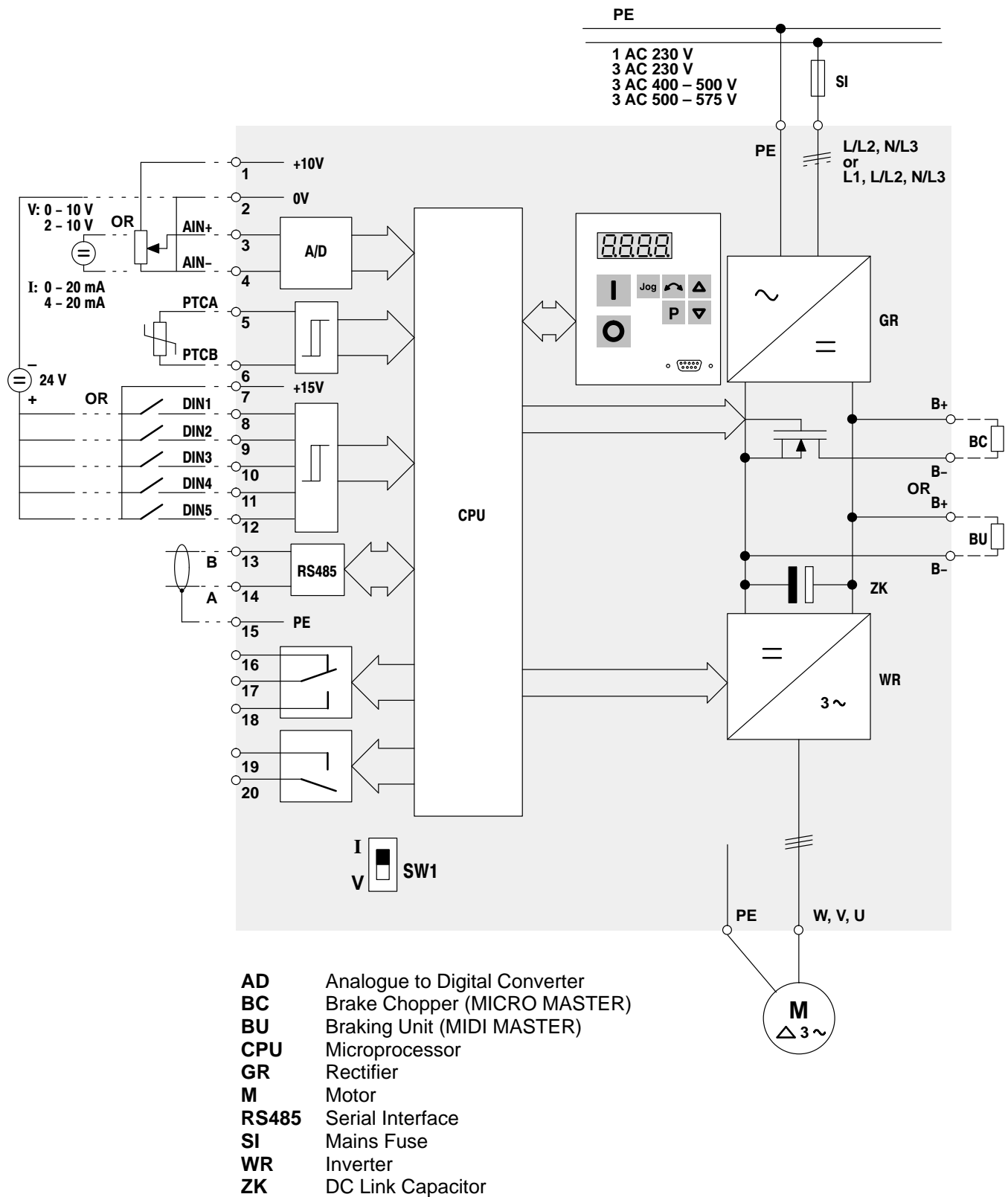

Figure 1: MICRO MASTER / MIDI MASTER Block Diagram

1.2 Options

The following options are available for the MICRO MASTER and MIDI MASTER:

- Braking resistor (MICRO MASTER)
- Braking unit (MIDI MASTER)
- RFI suppression filter
- Enhanced operator panel

1.3 MICRO MASTER and MIDI MASTER Variants

This handbook covers all variants of the MICRO MASTER and MIDI MASTER inverters as listed below:

MICRO MASTER				MIDI MASTER			
Model	Input Voltage	Power Rating	Order No.	Model	Input Voltage	Power Rating	Order No.
MM25	230 V 1 AC	250 W	6SE3111-5BA40	MD550/2	230 V 3 AC	5.5 kW	<i>see Note below</i>
MM25/2	230 V 3 AC		6SE3111-5CA40	MD750/2		7.5 kW	
MM37	230 V 1 AC	370 W	6SE3112-1BA40	MD1100/2		11.0 kW	
MM37/2	230 V 3 AC		6SE3112-1CA40	MD1500/2		15.0 kW	
MM55	230 V 1 AC	550 W	6SE3112-8BA40	MD1850/2		18.5 kW	
MM55/2	230 V 3 AC		6SE3112-8CA40	MD2200/2		22.0 kW	
MM75	230 V 1 AC	750 W	6SE3113-6BA40	MD750/3	400 – 500 V 3 AC	7.5 kW	6SE3121-7DG40
MM75/2	230 V 3 AC		6SE3113-6CA40	MD1100/3		11.0 kW	6SE3122-4DG40
MM110	230 V 1 AC	1.1 kW	6SE3115-2BB40	MD1500/3		15.0 kW	6SE3123-0DH40
MM110/2	230 V 3 AC		6SE3115-2CB40	MD1850/3		18.5 kW	6SE3123-5DH40
MM150	230 V 1 AC	1.5 kW	6SE3116-8BB40	MD2200/3		22.0 kW	6SE3124-2DJ40
MM150/2	230 V 3 AC		6SE3116-8CB40	MD3000/3		30.0 kW	6SE3125-5DJ40
MM220	230 V 1 AC	2.2 kW	6SE3121-0BC40	MD3700/3	37.0 kW	6SE3126-8DJ40	
MM220/2	230 V 3 AC		6SE3121-0CC40	MD750/4	7.5 kW	<i>see Note below</i>	
MM300/2	230 V 3 AC	3.0 kW	6SE3121-3CC40	MD1100/4	11.0 kW		
MM150/3	400 – 500 V 3 AC	1.5 kW	6SE3114-0DC40	MD1500/4	15.0 kW		
MM220/3		2.2 kW	6SE3115-8DC40	MD1850/4	18.5 kW		
MM300/3		3.0 kW	6SE3117-3DC40	MD2200/4	22.0 kW		
MM400/3		4.0 kW	6SE3121-0DC40	MD3000/4	30.0 kW		
MM550/3		5.5 kW	6SE3121-3DC40	MD3700/4	MD3700/4	37.0 kW	
						37.0 kW	

Note

Please check with your Siemens dealer for availability of these variants.

Many aspects of operation are common to all variants. However, some differences do exist (particularly in installation procedures). These differences are described at the appropriate places in the text.

2. INSTALLATION



WARNING



To guarantee the safe operation of the equipment it must be installed and commissioned properly by qualified personnel in compliance with the warnings laid down in these operating instructions.

Take particular note of the general and regional installation and safety regulations regarding work on high voltage installations (e.g. VDE), as well as the relevant regulations regarding the correct use of tools and personal protective gear.

Make sure that the unobstructed clearance for each of the cooling inlets and outlets above and below the inverter is at least 100 mm.

Ensure that the temperature does not exceed the specified level when the inverter is installed in a cubicle.

Avoid excessive vibration and shaking of the equipment.

Inverter models MM25, MM37, MM55 and MM75 **must** be fixed securely to a flat surface before use to prevent access to the capacitors contained within the heatsink.

Note: Consider the possible use of options (e.g. RFI suppression filters) at the planning stage.

2.1 Wiring Guidelines to Minimise the Effects of EMI

The inverters are designed to operate in an industrial environment where a high level of Electro-Magnetic Interference (EMI) can be expected. Usually, good installation practices will ensure safe and trouble-free operation. However, if problems are encountered, the following guidelines may prove useful. In particular, grounding of the system 0V at the inverter, as described below, may prove effective.

- (1) Ensure that all equipment in the cubicle is well earthed using short, thick earthing cable connected to a common star point or busbar. It is particularly important that any control equipment that is connected to the inverter (such as a PLC) is connected to the same earth or star point as the inverter via a short, thick link. Flat conductors (e.g. metal brackets) are preferred as they have lower impedance at high frequencies.
The return earth from motors controlled by the inverters should be connected directly to the earth connection (PE) on the associated inverter.
- (2) Use saw-tooth washers when mounting the inverter and ensure that a good electrical connection is made between the heatsink and the panel, removing paint if necessary.
- (3) Wherever possible, use screened leads for connections to the control circuitry. Terminate the ends of the cable neatly, ensuring that long strands of unscreened wire are not left visible.
- (4) Separate the control cables from the power connections as much as possible, using separate trunking, etc. If control and power cables cross, arrange the cables so that they cross at 90° if possible.
- (5) Ensure that contactors in the cubicle are suppressed, either with R-C suppressors for AC contactors or 'flywheel' diodes for DC contactors, **fitted to the coils**. Varistor suppressors are also effective. This is particularly important if the contactors are controlled from the relays on the inverter.
- (6) Use screened or armoured cables for the power connections and ground the screen at both ends.
- (7) If the drive is to be operated in a noise-sensitive environment, the RFI filter kit should be used to reduce the conducted and radiated interference from the inverter. In this case, the filter should be mounted as close to the inverter as possible and well grounded (*see (2) above*) and the supplied metallised cover should be fitted to the inverter.
- (8) Select the lowest switching frequency possible. This will reduce the amount of EMI generated by the inverter.

On no account must safety regulations be compromised when installing inverters!

2.2 Mechanical Installation

Mount the MICRO MASTER or MIDI MASTER in accordance with Figure 2 or Figure 3.

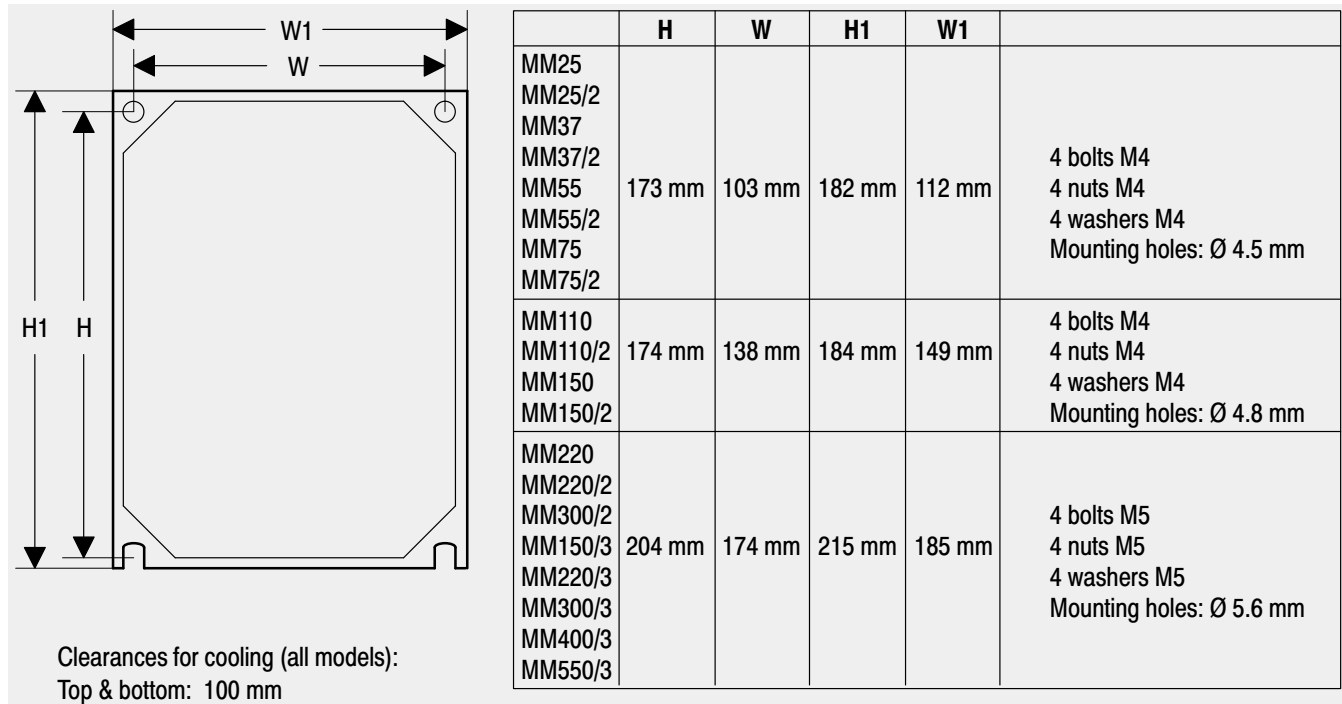

Figure 2: Mechanical Installation Diagram – MICRO MASTER

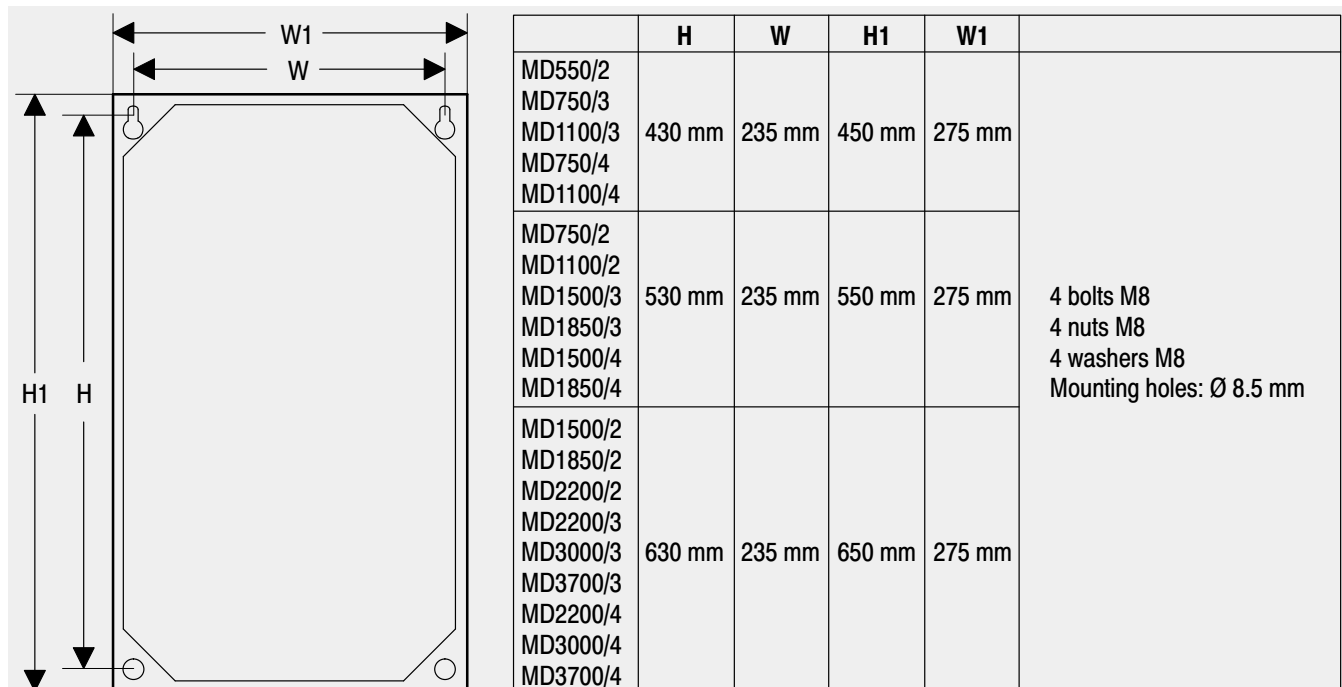

Figure 3: Mechanical Installation Diagram – MIDI MASTER

2.3 Electrical Installation – MICRO MASTER

The cover must be removed to connect the electrical leads. The cover on the MICRO MASTER is attached to the heatsink by a single M4 screw which is located below the STOP button (see Figure 10). Remove the screw and then lift off the cover. The electrical terminals are now exposed (see Figure 4).

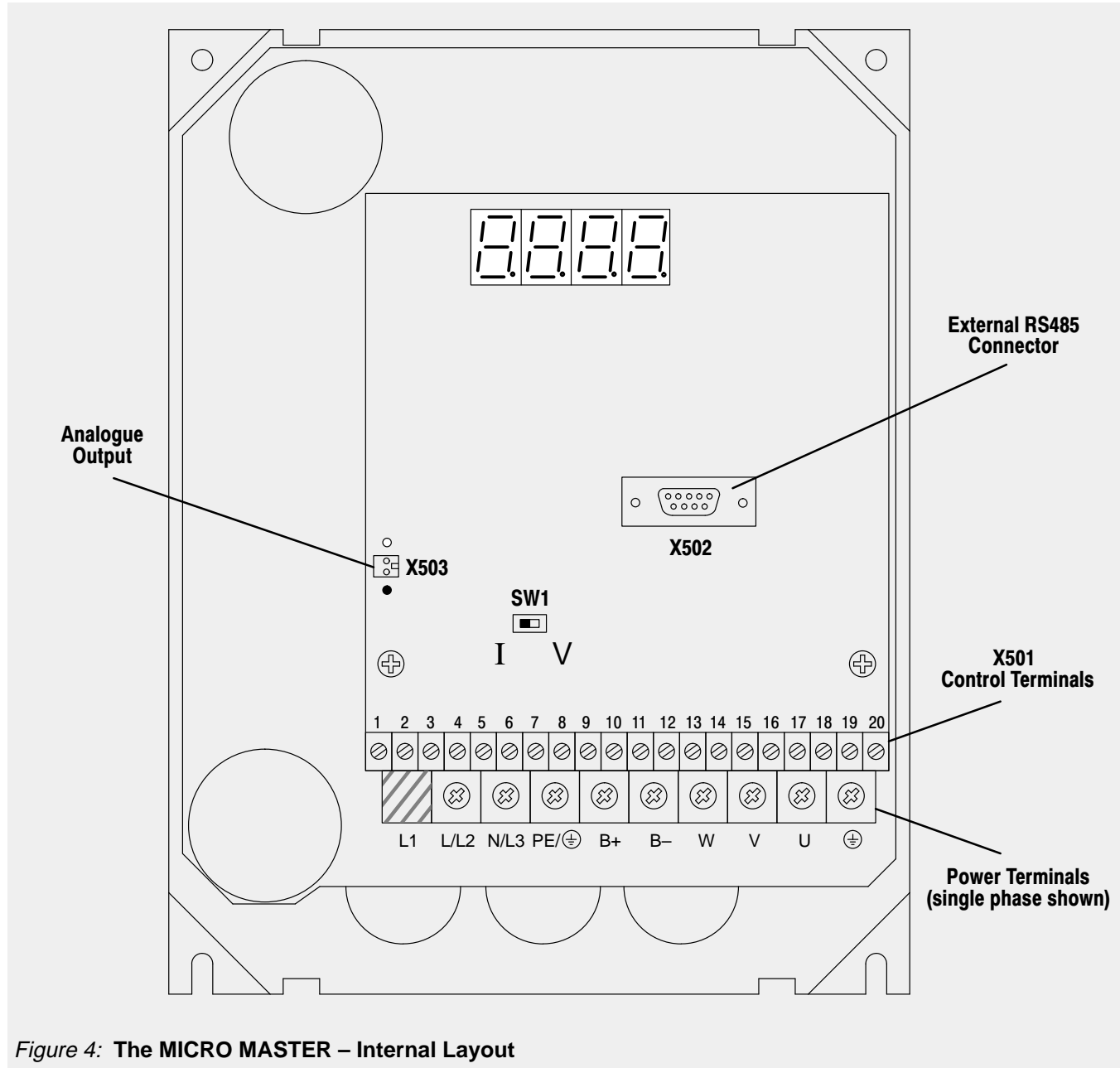

Figure 4: The MICRO MASTER – Internal Layout



CAUTION

The printed circuit boards contain CMOS components that are particularly sensitive to static electricity. For this reason, avoid touching the boards or components with your hands or metal objects. Only the terminal screws may be touched with insulated screwdrivers when connecting the cables. Ensure that the cover is not tilted or skewed when refitted.

Feed the cables into the inverter from the bottom and connect them to the power and control terminal blocks in accordance with the information supplied in sections 2.3.1 and 2.3.2. Ensure that the leads are connected correctly and the equipment is properly earthed.

**CAUTION**

The control, power supply and motor leads must be laid separately. They must not be fed through the same cable conduit/trunking.

Use screened cable for the control lead.

Use Class 1 60/75°C copper wire only. Tightening torque for the field wiring terminals is 1.1 Nm.

The MICRO MASTER is suitable for use in a circuit capable of delivering not more than 1000/5000 A symmetrical (rms), 230/415 V maximum, when protected by a time delay fuse, as listed below:

	Mains Input	Model	Fuse Rating
1000 A	230 V, 1 AC	MM25	10 A
		MM37	
		MM55	
		MM75	16 A
5000 A	230 V, 1 AC	MM110	20 A
		MM150	
		MM220	25 A
1000 A	230 V, 3 AC	MM25/2	10 A
		MM37/2	
		MM55/2	
		MM75/2	
		MM110/2	16 A
5000 A	230 V, 3 AC	MM150/2	20 A
		MM220/2	
		MM300/2	20 A
1000 A	400 – 500 V, 3 AC	MM150/3	10 A
		MM220/3	16 A
		MM300/3	
5000 A	400 – 500 V, 3 AC	MM400/3	20 A
		MM550/3	

To tighten up the terminal screws use: **power terminals** – cross-tip screwdriver 4 – 5 mm
control terminals – small blade screwdriver 2 – 2.5 mm

2.3.1 Power and Motor Connections

Ensure that the power source supplies the correct voltage and is designed for the necessary current (*see section 1.3*). Ensure that the appropriate circuit-breakers with the specified current rating are connected between the power supply and inverter (*see section 7.1*).

Connect the power input to the power terminals L/L2 – N/L3 (1 phase) or L1, L/L2, N/L3 (3 phase), and earth using a 3-core cable for single phase units or a 4-core cable for three phase units. For cross-section of each core see section 7.1.

Use a 4-core cable to connect the motor. As shown in Figure 5, the cable is connected to the power terminals W/V/U and the earth.

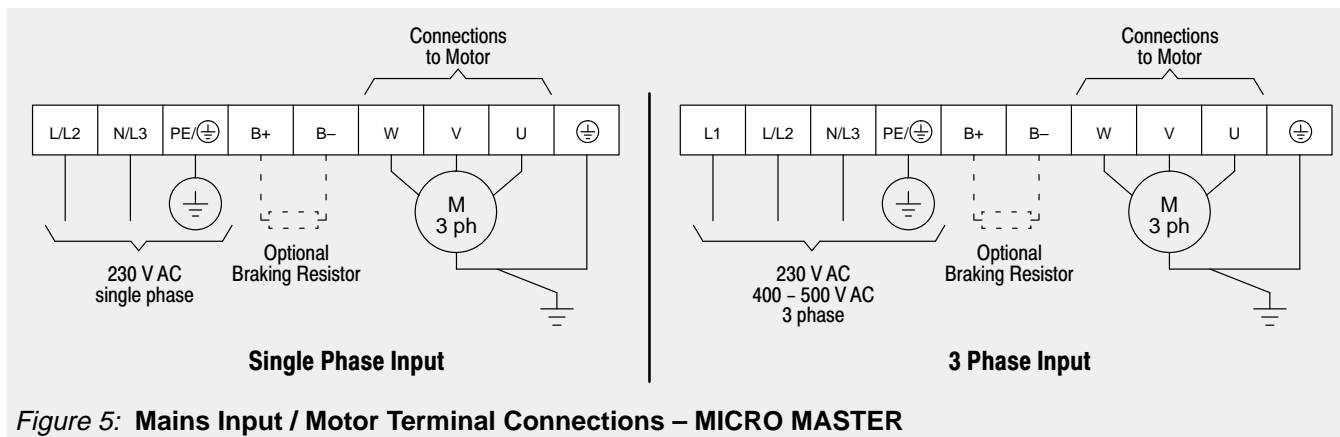

Figure 5: Mains Input / Motor Terminal Connections – MICRO MASTER

The total length of the motor lead should not exceed 50 m. If a screened motor lead is used, the maximum length should be 25 m. Consult your service department if you wish to use longer leads.

Asynchronous and synchronous motors can be connected to the MICRO MASTER inverter either individually or in parallel.

WARNING

Ensure that motor is configured for the correct supply voltage. When synchronous machines are connected or when coupling several motors in parallel, the inverter must be operated with voltage/frequency control characteristic (P077= 0 or 2) and slip compensation must be disabled (P071 = 0).

2.3.2 Control Connections

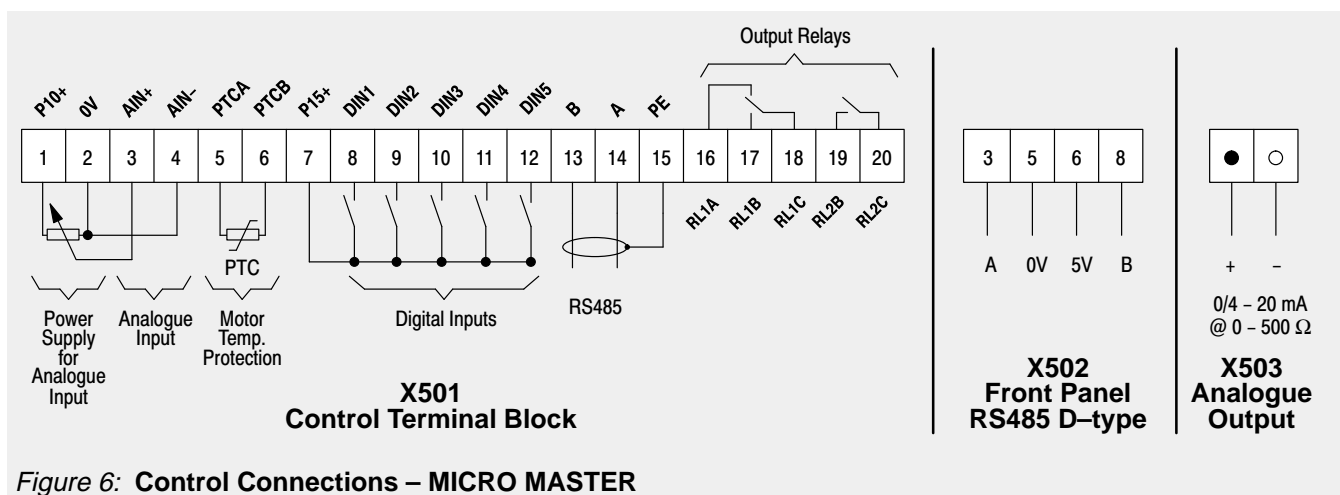

Figure 6: Control Connections – MICRO MASTER

Note

Do not use the internal RS485 connections (terminals 13 and 14) if you intend using the external RS485 connection on the front panel.

Control Terminal (X501)	Description	Value	Function	Notes
1	P10+	+10 V	Power supply	Max. 3 mA
2	0V	0 V	Power supply	Ground
3	AIN+	0 – 10 V/0 – 20 mA or 2 – 10 V/4 – 20 mA	Analogue input	+ connection
4	AIN–		Analogue input	– connection
5	PTCA		Motor PTC input	
6	PTCB		Motor PTC input	
7	P15+	+15 V	Power supply for DIN1 – 5	Max. 20 mA
8	DIN1		Digital input 1	13 – 33 V
9	DIN2		Digital input 2	13 – 33 V
10	DIN3		Digital input 3	13 – 33 V
11	DIN4		Digital input 4	13 – 33 V
12	DIN5		Digital input 5	13 – 33 V
13	B		RS485 'B' wire	For USS protocol
14	A		RS485 'A' wire	For USS protocol
15	PE		Protective earth	
16	RL1A		Relay 1	Normally closed
17	RL1B		Relay 1	Normally open
18	RL1C		Relay 1	Common
19	RL2B		Relay 2	Normally open
20	RL2C		Relay 2	Common

2.4 Electrical Installation – MIDI MASTER

The cover must be removed to connect the electrical leads. The cover on the MIDI MASTER is attached to the heatsink by five or seven M4 screws, depending on the variant. Two or three screws are located on the left and right-hand sides of the cover and there is a single central screw located below the STOP button (see Figure 10). Remove each of the screws and then lift off the cover. The electrical terminals are now exposed (see Figure 7).



CAUTION

On the printed circuit boards that are now exposed are highly sensitive CMOS components that are particularly sensitive to static electricity. For this reason, avoid touching the boards or components with your hands or metal objects. Only the terminal screws may be touched with insulated screwdrivers when connecting the leads.

The power, control and motor cables enter the inverter from the bottom. When connecting them to the appropriate terminal blocks ensure that they are connected correctly and that the equipment is properly earthed.



CAUTION

The control, power supply and motor leads must be laid separately. They must not be fed through the same cable conduit/trunking.

Use screened cable for the control lead.

Use Class 1 60/75°C copper wire only. Tightening torque for the field wiring terminals is 1.1 Nm.

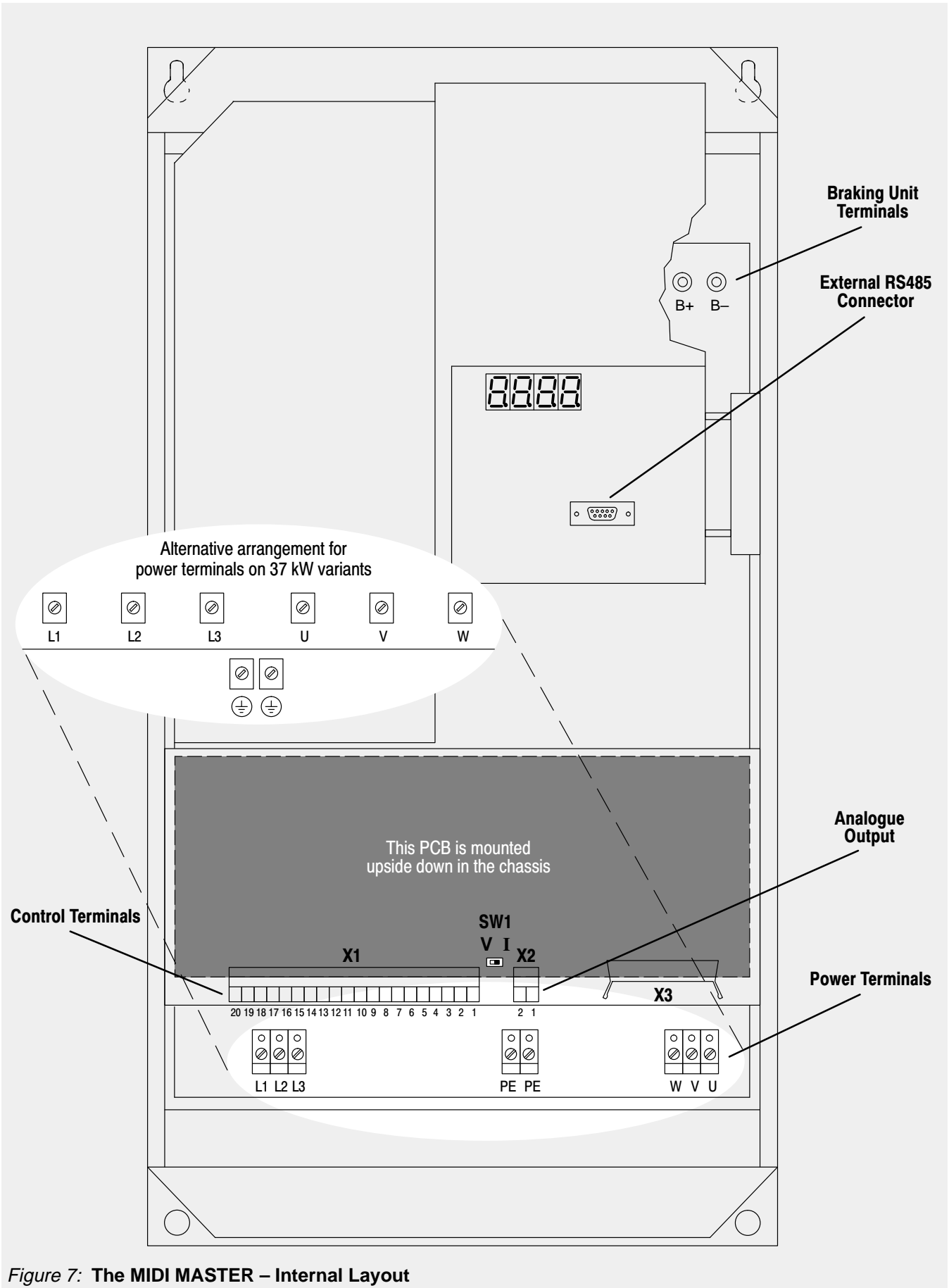

Figure 7: The MIDI MASTER – Internal Layout

The MIDI MASTER is suitable for use in a circuit capable of delivering not more than 5000 A symmetrical (rms), 550 V maximum, when protected by a time delay fuse, as listed below:

	Mains Input	Model	Fuse Rating	
5000 A	230 V, 3 AC	MD550/2	Data not yet available	
		MD750/2		
		MD1100/2		
		MD1500/2		
		MD1850/2		
		MD2200/2		
	400 – 500 V, 3 AC	MD750/3	32 A	
		MD1100/3		
		MD1500/3	50 A	
		MD1850/3		
		MD2200/3	80 A	
		MD3000/3		
	575 V, 3 AC	MD3700/3	100 A	
		MD750/4	Data not yet available	
				MD1100/4
				MD1500/4
				MD1850/4
				MD2200/4
MD3000/4				
MD3700/4				

To tighten up the terminal screws use: **power terminals** – small or medium blade screwdriver 3 – 7 mm
(depends on inverter variant)
control terminals – small blade screwdriver 2 – 2.5 mm

2.4.1 Power and Motor Connections

Make sure that the power source supplies the correct voltage and is designed for the necessary current (see section 1.3). Ensure that the appropriate circuit-breakers with the specified current rating are connected between the power supply and inverter (see section 7.1).

Connect the power input to the power terminals L1, L2, L3 and earth using a 4-core cable. For cross-section of each core see section 7.1.

Use a 4-core cable to connect the motor. As indicated in Figure 8, the cable is connected to the power terminals W/V/U and the separate earth.

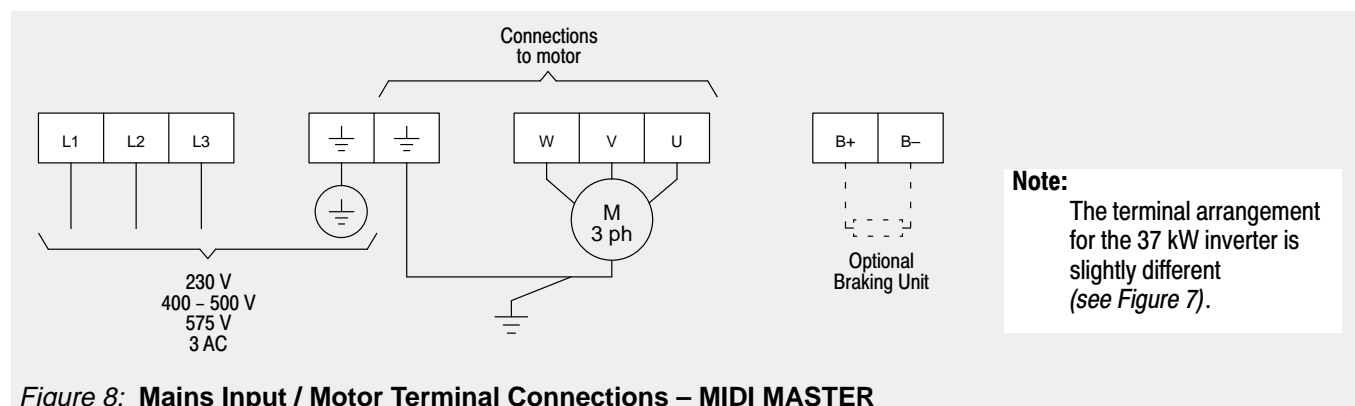



Figure 8: Mains Input / Motor Terminal Connections – MIDI MASTER

The total length of the motor lead should not exceed 50 m. If a screened motor lead is used, the maximum length should be 25 m. Consult your service department if you wish to use longer leads.

Asynchronous and synchronous motors can be connected to the MIDI MASTER inverter either individually or in parallel.

	<p>WARNING</p> <p>Ensure that motor is configured for correct supply voltage. When synchronous machines are connected or when coupling several motors in parallel, the inverter must be operated with voltage/frequency control characteristic (P077= 0 or 2) and slip compensation must be disabled (P071 = 0).</p>
---	---

2.4.2 Control Connections

These connections are identical to those on the MICRO MASTER (see section 2.3.2), but note the following points:

- (1) The RS485 D-type connector is mounted on a separate PCB.
- (2) The X1 and X2 terminal blocks are of a two-part design. The part containing the screw terminals must be unplugged from its housing on the PCB before the wires can be connected. Once all connections to the terminals have been made, plug the terminal block back into its housing.

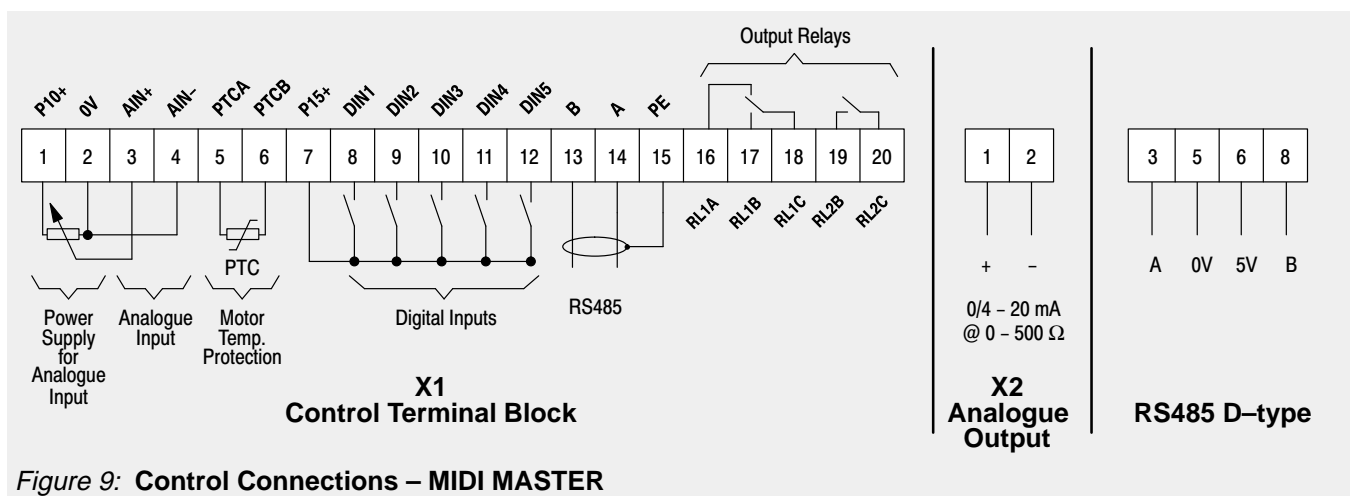

Figure 9: Control Connections – MIDI MASTER

Note

Do not use the internal RS485 connections (terminals 13 and 14) if you intend using the external RS485 connection on the front panel.

3. FRONT PANEL CONTROLS



WARNING

The equipment must not be switched on until after its plastic cover has been fitted.

After the power has been turned off, you must always wait five minutes so that the dc-link capacitors can discharge. Do not remove the cover until this time has elapsed.

As a precautionary measure, the digital frequency setpoint has been set at 0.0 Hz in the factory. This prevents inadvertent and uncontrolled running of the motor occurring at initial start-up.









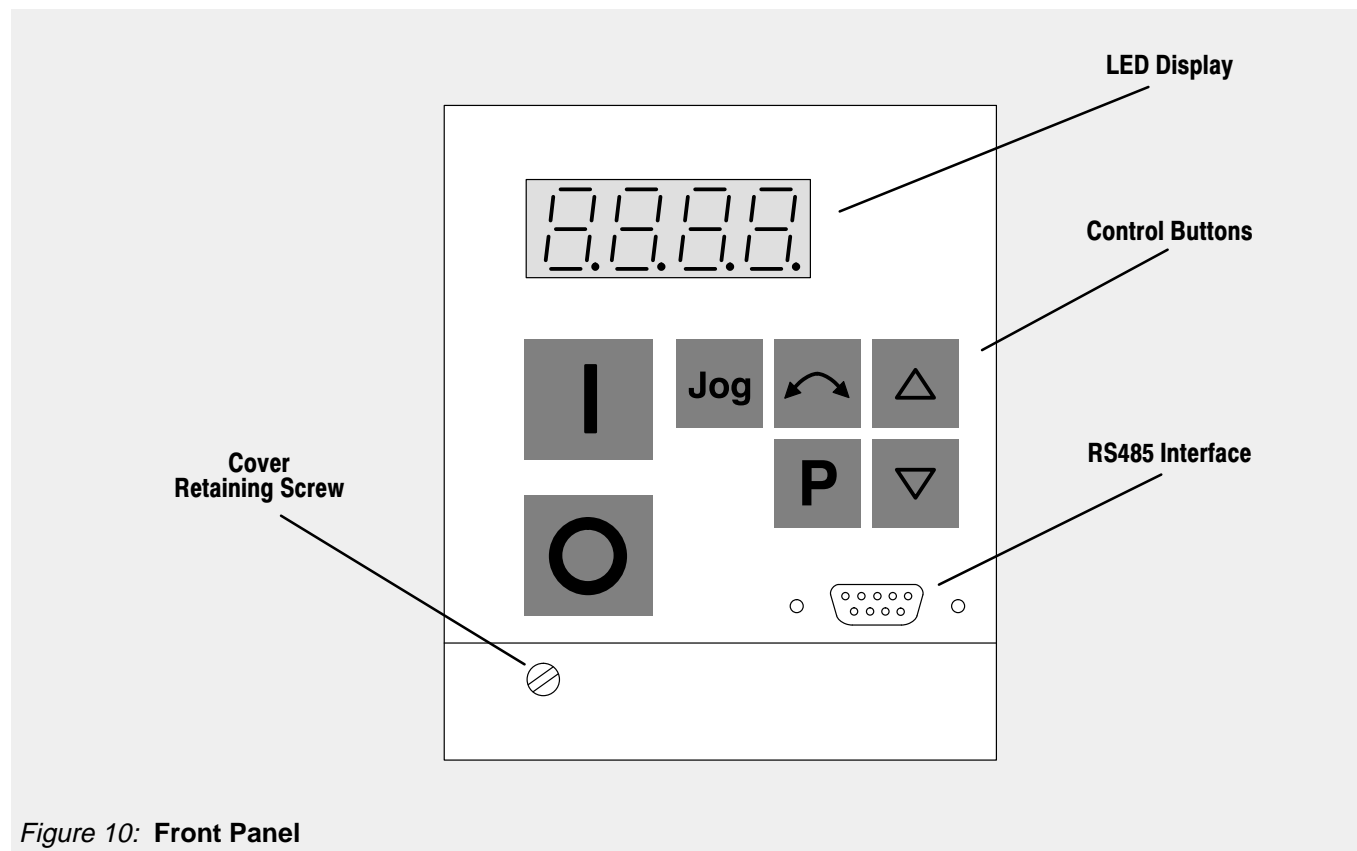

Before the motor will run it is necessary to enter a frequency setpoint via parameter P000 with the Δ button, or to set it with parameter P005.

All settings must only be entered by qualified personnel, paying particular attention to the safety precautions and warnings.

The parameter settings required can be entered using the three parameterisation buttons (**P**, Δ and ∇) on the front panel of the inverter (Figure 11 contains a flowchart for the procedure for setting parameter values). The parameter numbers and values are indicated on the four digit LED display.

Switch SW1 selects between voltage (V) and current (I) analogue inputs. This switch can only be accessed while the cover is removed (see Figure 4 (MICRO MASTER) or Figure 7 (MIDI MASTER) for location).

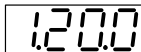

	RUN Button	Press to start the inverter. The operation of this button can be selectively disabled by setting P121 = 0.
	STOP Button	Press to stop the inverter.
	Parameterisation Button	Press to toggle between parameter number and parameter value.
	UP Button	Press to set parameter numbers, parameter index numbers and parameter values to <i>higher</i> values. The facility to use this button to change the frequency can be selectively disabled by setting P124 = 0.
	DOWN Button	Press to set parameters numbers, parameter index numbers and parameter values to <i>lower</i> values.
	JOG Button	Pressing this button while the inverter is stopped causes it to start and run at the preset frequency. The inverter stops as soon as the button is released. Pressing this button while the inverter is running has no effect. The operation of this button can be selectively disabled by setting P123 = 0.
	FORWARD/REVERSE Button	Press to change the direction of rotation of the motor. If REVERSE is selected, the LED display will indicate this by prefixing a minus sign (-) to the value displayed up to 99.9, or will display a flashing decimal point after the left-hand digit for values of 100.0 or greater. e.g. 60.0 Hz in reverse mode =  120.0 Hz in reverse mode =  The operation of this button can be selectively disabled by setting P122 = 0.
	4-digit LED display	Displays parameter number (P000 – P944), parameter value (000.0 – 999.9) or fault code (F000 – F154). Note: Although the LED display only displays frequency values to a resolution of 0.1 Hz, you can increase the resolution to 0.01 Hz (see Note [6] in Figure 11 for the procedure).

IMPORTANT: Parameters above P009 cannot be adjusted unless P009 is first set to 002 or 003.

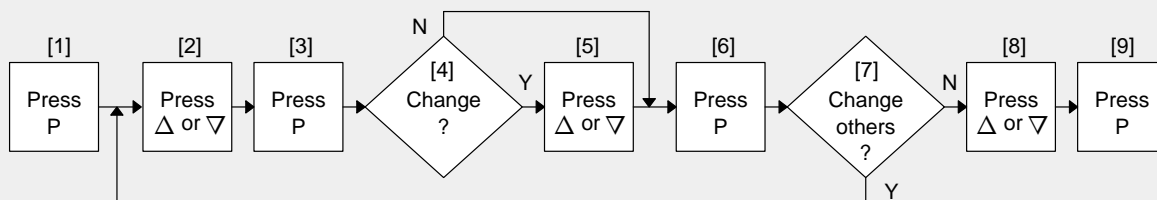

Notes

- [1] Display changes to 'P000'.
- [2] Select the parameter to change.
- [3] View the value of the parameter currently selected.
- [4] Do you wish to change the value? If not, go to [6].
- [5] Increase (Δ) or decrease (∇) the value of the parameter.
- [6] 'Lock' the new value into memory (if changed) and return to the parameter display.
Note
To increase the resolution to 0.01 when changing frequency parameters, instead of pressing P momentarily to return to the parameter display, keep the button pressed until the display changes to '-.n0' (n = the current tenths value, e.g. if the parameter value = '055.8' then n = 8). Press Δ or ∇ to change the value (all values between .00 and .99 are valid) and then press P twice to return to the parameter display.
- [7] Do other parameters need changing? If so, return to [2].
- [8] Scroll up or down until 'P944' or 'P000' is displayed. If you scroll upwards, the display stops automatically at P944. However, pressing the Δ button again causes the display to 'wrap around' to P000.
- [9] Exit from the procedure and return to the normal operating display.

If parameters are changed accidentally, all parameters can be reset to their default values by setting parameter **P944** to 1 and then pressing **P**.

Figure 11: Procedure for Changing Parameter Values

4. OPERATING INFORMATION

Refer to the parameter list in section 5 for a full description of each parameter.

4.1 General

- (1) The inverter does not have a main power switch and is therefore live when the mains supply is connected. It waits with the output disabled for the RUN button to be pressed or for an ON signal via terminal 8 (rotate right) or terminal 9 (rotate left) – see parameters P051 – P055.
- (2) If output frequency (P001 = 0) is selected as the display, the corresponding setpoint is displayed approximately every 1.5 seconds while the inverter is stopped.
- (3) The inverter is programmed at the factory for standard applications on Siemens four-pole standard motors. When using other motors it is necessary to enter the specifications from the motor's rating plate into parameters P081 to P085 (see Figure 12). Note that access to these parameters is not possible unless P009 has been set to 002 or 003.

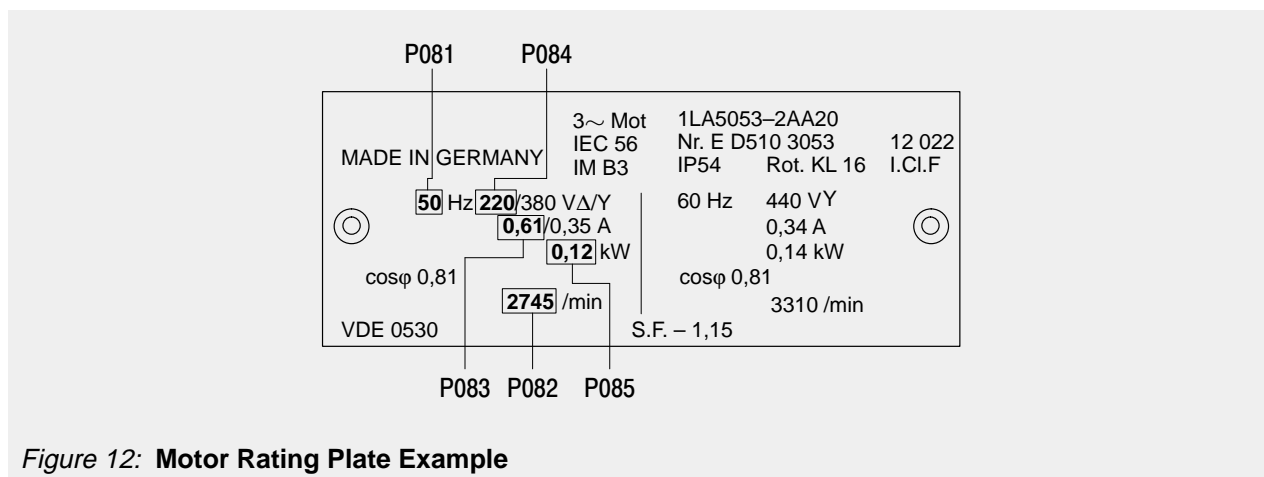

Figure 12: Motor Rating Plate Example

Note: Ensure that the motor is configured correctly, i.e. in the above example connection is for 220 V.

- (4) When delivered, the inverter's frequency setpoint is set to 0.00 Hz, which means that the motor will not rotate! To make it start up, a setpoint must be entered using the Δ button or entering a value in P005.
- (5) When a parameter value has been set, it is stored automatically in the internal memory.

4.2 Basic Operation

The most basic method of setting up the inverter for use is described below. This method uses a digital frequency setpoint and requires only the minimum number of parameters to be changed from their default settings.

- (1) Apply mains power to the inverter. Set parameter P009 to 002 or 003 to enable all parameters to be adjusted (see Figure 11 for the procedure).
- (2) Set parameter P005 to the desired frequency setpoint.
- (3) Check parameters P081 to P085 and ensure that they match the requirements stated on the rating plate on the motor (see Figure 12).
- (4) Press the RUN button (I) on the inverter's front panel. The inverter will now drive the motor at the frequency set by P005.

If required, the motor's speed (i.e. frequency) can be varied directly by using the Δ ∇ buttons. (Set P011 to 001 to enable the new frequency setting to be retained in memory during periods when the inverter is not running.)

4.3 Operation – Digital Control

For a basic startup configuration using digital control, proceed as follows:

- (1) Connect control terminal 7 to terminal 8 via a simple on/off switch. This sets up the inverter for clockwise rotation (default).
- (2) Refit the cover and then apply mains power to the inverter. Set parameter P009 to 002 or 003 to enable all parameters to be adjusted (see Figure 11 for the procedure).
- (3) Check that parameter P006 is set to 000 to specify digital setpoint.
- (4) Set parameter P007 to 001 to specify digital input (i.e. DIN1 (terminal 8) in this case) and disable the front panel controls.
- (5) Set parameter P005 to the desired frequency setpoint.
- (6) Set parameters P081 to P085 in accordance with the rating plate on the motor (see Figure 7).
- (7) Set the external on/off switch to ON. The inverter will now drive the motor at the frequency set by P005.

If required, the motor's speed (i.e. frequency) can be varied directly by using the Δ ∇ buttons. (Set P011 to 001 to enable the new frequency setting to be retained in memory during periods when the inverter is not running.)

4.4 Operation – Analogue Control

For a basic startup configuration using analogue voltage control, proceed as follows:

- (1) Connect control terminal 7 to terminal 8 via a simple on/off switch. This sets up the motor for clockwise rotation (default).
- (2) Connect a 4.7 k Ω potentiometer to the control terminals as shown in Figure 6 (MICRO MASTER) or Figure 9 (MIDI MASTER) or connect a 0 – 10 V signal from pin 2 (0V) to pin 3.
- (3) Set the position of SW1 for voltage (V) input.
- (4) Refit the cover and then apply mains power to the inverter. Set parameter P009 to 002 or 003 to enable all parameters to be adjusted (see Figure 11 for the procedure).
- (5) Set parameter P006 to 001 to specify analogue setpoint.
- (6) Set parameters P021 and P022 to specify the minimum and maximum output frequency settings.
- (7) Set parameters P081 to P085 in accordance with the rating plate on the motor (see Figure 12).
- (8) Set the external on/off switch to ON. Turn the potentiometer (or adjust the analogue control voltage) until the desired frequency is displayed on the inverter.

4.5 Stopping the Motor

Stopping can be achieved in several ways:

- Going down to 0.0 Hz (lowering the setpoint to 0.0 with the ∇ button causes the motor to come to a slow, controlled stop).
- Cancelling the ON command or pressing the OFF button (O) on the front panel causes the inverter to ramp down at the selected ramp down rate (see P003).
- OFF2 – operation causes the motor to coast to a standstill (see parameters P051 to P055).
- OFF3 – operation causes rapid braking (see parameters P051 to P055).
- DC injection braking up to 250% causes an abrupt stop after cancellation of the ON command (see P073).
- Resistive braking (see parameter P075).

4.6 If the Motor Does Not Start Up

If the motor does not start up when the ON command has been given, check if a frequency setpoint has been entered in P005 and that the motor specifications have been entered correctly under parameters P081 to P085.

If the inverter is configured for operation via the front panel (P007 = 001) and the motor does not start when the RUN button is pressed, check that P121 = 001 (RUN button enabled).

If the motor does not run after parameters have been changed accidentally, reset the inverter to the factory default parameter values by setting parameter **P944** to **001** and then pressing **P**.

4.7 Local and Remote Control

The inverter can be controlled either locally (default), or remotely via a USS data line connected to the internal interface terminals (13 and 14) or to the RS485 D-type connector on the front panel.

When local control is used, the inverter can only be controlled via the front panel or the control terminals. Control commands, setpoints or parameter changes received via the RS485 interface have no effect.

For remote control, the serial interface is designed as a 2-wire connection for bi-directional data transmission. Three different methods of remote control are possible, depending on the setting of parameter P910 (*refer to parameter P910 in section 5*).

Note: Only one RS485 connection is allowed. You can use either the front panel D-type interface or terminals 13 and 14 **but not both**.

When operating via remote control the inverter will not accept control commands from the terminals. *Exception: OFF2 or OFF3 can be activated via parameters P051 to P055 (refer to parameters P051 to P055 in section 5).*

Several inverters can be connected to an external control unit at the same time. The inverters can be addressed individually.

Note: If the inverter has been set up to operate via the serial link but does not run when an ON command is received, it is possible that the connections to terminals 13 and 14 may need to be swapped over.

For further information, refer to the following documents:

E20125-B0001-S302-A1	Application of the USS Protocol in SIMOVERT Units 6SE21 and MICRO MASTER (German)
E20125-B0001-S302-A1-7600	Application of the USS Protocol in SIMOVERT Units 6SE21 and MICRO MASTER (English)

5. SYSTEM PARAMETERS

Parameters can be changed and set using the membrane-type buttons to adjust the desired properties of the inverter, such as ramp times, minimum and maximum frequencies, etc. The parameter numbers selected and the setting of the parameter values are indicated in the four digit LED display.

Note: If you press the Δ or ∇ button momentarily, the values change step by step. If you keep the buttons pressed for a longer time, the values scroll through rapidly.

Access to parameters is determined by the value set in P009. Check that the key parameters necessary for your application have been programmed.

P009 options are:

- 0 = Only the parameters from P001 to P009 can be read and set.
- 1 = Parameters P001 to P009 can be set and all other parameters can only be read.
- 2 = All parameters can be set, but P009 resets to 0 the next time power is removed from the inverter.
- 3 = All parameters can always be set.

Note: In the following parameter table:

- '•' Indicates parameters that can be changed during operation.
- '☆☆☆☆' Indicates that the value of this factory setting depends on the rating of the inverter.

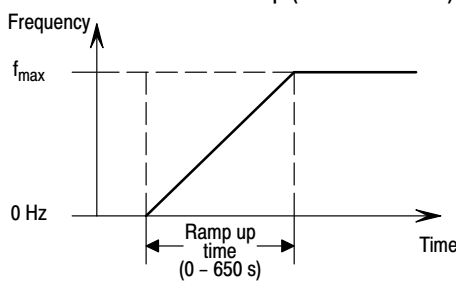
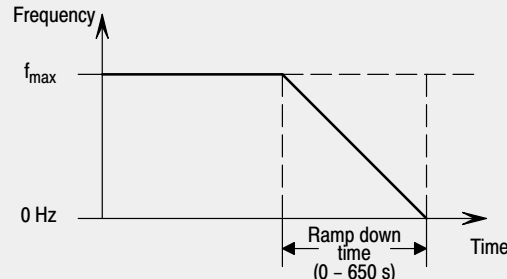
Parameter	Function	Range [Default]	Description / Notes
P000	Operating display	-	This displays the output selected in P001. In the event of a failure, the relevant error message (Fnnn) is displayed (see section 6). In the event of a warning the display flashes. If output frequency has been selected (P001 = 0), the corresponding setpoint flashes about every 1.5 seconds when the inverter is stopped.
P001 •	Display selection	0 – 6 [0]	Display selection: 0 = Output frequency 1 = Frequency setpoint (i.e. speed at which inverter is set to run) 2 = Motor current 3 = DC-link voltage 4 = Motor torque (% nominal) 5 = Motor RPM 6 = USS status
P002 •	Ramp up time (seconds)	0 – 650.0 [10.0]	This is the time taken for the motor to accelerate from standstill to the maximum frequency as set in P013. Setting the ramp up time too short can cause the inverter to trip (fault code F002). 
P003 •	Ramp down time (seconds)	0 – 650.0 [10.0]	This is the time taken for the motor to decelerate from maximum frequency (P013) to standstill. Setting the ramp down time too short can cause the inverter to trip (fault code F001). 

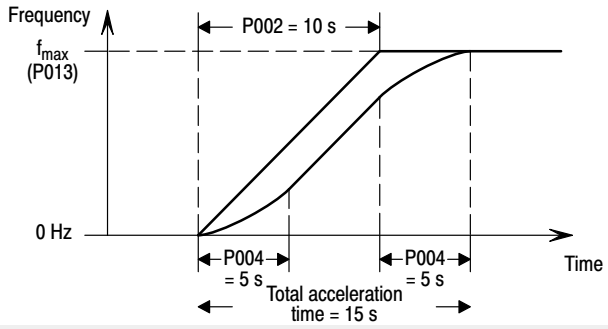
Parameter	Function	Range [Default]	Description / Notes
P004 •	Smoothing (seconds)	0 – 40.0 [0.0]	Used to smooth the acceleration of the motor (useful in applications where it is important to avoid 'jerking', e.g. conveyor systems, textiles, etc.). 
P005 •	Digital frequency setpoint (Hz)	0 – 650.00 [0.00]	Sets the speed that the inverter will run at when operated in digital mode. Only effective if P006 set to '0'.
P006	Frequency setpoint type selection	0 – 2 [0]	Sets the control mode of the inverter: 0 = Digital. The inverter runs at the speed set in P005. The speed can be adjusted using the Δ and ∇ buttons. 1 = Analogue. Control via analogue input signal. 2 = Fixed frequency or motor potentiometer, depending on the value of the binary inputs (P051 – P055). Note: If P006 = 1 and the inverter is set up for remote control operation, the analogue inputs remain active.
P007	Enable/disable front panel buttons	0 – 1 [1]	0 = Front panel buttons disabled (determined by setting of parameters P121 – P124). Control is via digital inputs. 1 = Front panel buttons enabled.
P009 •	Parameter protection setting	0 – 3 [0]	Determines which parameters can be adjusted: 0 = Only parameters from P001 to P009 can be read/set. 1 = Parameters from P001 to P009 can be set and all other parameters can only be read. 2 = All parameters can be read/set but P009 automatically resets to 0 when power is removed. 3 = All parameters can be read/set.
P011	Frequency setpoint memory	0 – 1 [0]	0 = Disabled 1 = Enabled after switch-off. i.e. The setpoint alterations made with the Δ / ∇ buttons are stored even when power has been removed from the inverter.
P012 •	Minimum motor frequency (Hz)	0 – 650.00 [0.00]	Sets the minimum motor frequency.
P013 •	Maximum motor frequency (Hz)	0 – 650.00 [50.00]	Sets the maximum motor frequency.
P014 •	Skip frequency (Hz)	0 – 650.00 [0.00]	A skip frequency can be set with this parameter, to avoid the effects of resonance of the inverter. Frequencies within +/- 2 Hz of this setting are suppressed. Stationary operation is not possible within the suppressed frequency range – the range is just passed through.
P015 •	Automatic restart	0 – 1 [0]	Setting this parameter to '1' enables the inverter to restart automatically after a mains break, provided the run/stop switch is still closed. 0 = Disabled 1 = Automatic restart

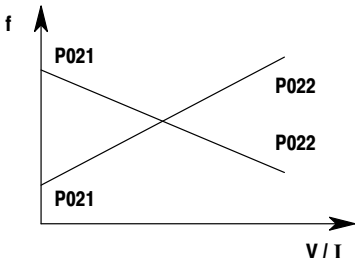
Parameter	Function	Range [Default]	Description / Notes															
P016 •	Start on the fly	0 – 2 [0]	<p>Allows the inverter to start onto a spinning motor. Under normal circumstances the inverter runs the motor up from 0 Hz. However, if the motor is still spinning or is being driven by the load, it will undergo braking before running back up to the setpoint – this can cause an overcurrent trip. By using a flying restart, the inverter ‘homes in’ on the motor’s speed and runs it up from that speed to the setpoint. (Note: If the motor has stopped or is rotating slowly, some ‘rocking’ may occur as the inverter senses the direction of rotation prior to restarting.)</p> <p>0 = Normal restart 1 = Flying restart after power up, fault or OFF2 (if P018 = 1). 2 = Flying restart every time (useful in circumstances where the motor can be driven by the load).</p>															
P017	Smoothing type	0 – 1 [0]	<p>0 = Continuous smoothing (as defined by P004). 1 = Discontinuous smoothing (i.e. smoothing is suspended when a reduction in the frequency setting is detected).</p> <p>Note: P004 must be set to a value > 0.0 for this parameter to have any effect.</p>															
P018	Automatic restart after fault	0 – 1 [0]	<p>Automatic restart after fault:</p> <p>0 = Disabled 1 = The inverter will attempt to restart up to 5 times after a fault. If the fault is not cleared after the 5th attempt, the inverter will remain in the fault state.</p>															
P021 •	Minimum analogue frequency (Hz)	0 – 650.00 [0.00]	<p>Frequency corresponding to the lowest analogue input value, i.e. 0 V/0 mA or 2 V/4 mA, determined by P023. This can be set to a higher value than P022 to give an inverse relationship between analogue input and frequency output (see diagram in P022).</p>															
P022 •	Maximum analogue frequency (Hz)	0 – 650.00 [50.00]	<p>Frequency corresponding to the highest analogue input value, i.e. 10 V or 20 mA, determined by P023. This can be set to a lower value than P021 to give an inverse relationship between analogue input and frequency output.</p> <p>i.e.</p> 															
P023 •	Analogue input type	0 – 2 [0]	<p>Sets analogue input type, depending on the position of switch SW1:</p> <table border="1" data-bbox="831 1571 1475 1768"> <tr> <td rowspan="2">P023 = 0</td> <td>0 V</td> <td>10 V</td> </tr> <tr> <td>0 mA</td> <td>20 mA</td> </tr> <tr> <td rowspan="2">P023 = 1</td> <td>2 V</td> <td>10 V</td> </tr> <tr> <td>4 mA</td> <td>20 mA</td> </tr> <tr> <td rowspan="2">P023 = 2</td> <td>2 V*</td> <td>10 V</td> </tr> <tr> <td>4 mA*</td> <td>20 mA</td> </tr> </table> <p>* The inverter will come to a controlled stop if V < 1 V or I < 2 mA.</p>	P023 = 0	0 V	10 V	0 mA	20 mA	P023 = 1	2 V	10 V	4 mA	20 mA	P023 = 2	2 V*	10 V	4 mA*	20 mA
P023 = 0	0 V	10 V																
	0 mA	20 mA																
P023 = 1	2 V	10 V																
	4 mA	20 mA																
P023 = 2	2 V*	10 V																
	4 mA*	20 mA																
P024 •	Analogue setpoint addition	0 – 1 [0]	<p>If the inverter is in fixed frequency/motor potentiometer mode (P006 = 2) then setting this parameter to ‘1’ causes the analogue input value to be added.</p> <p>0 = No addition 1 = Addition of the analogue setpoint to the fixed frequency or the motor potentiometer frequency.</p> <p>Note: By selecting a combination of reversed negative fixed frequency settings and analogue setpoint addition, it is possible to configure the inverter for ‘centre zero’ operation with a +/-5 V supply or a 0 – 10 V potentiometer so that the output frequency can be 0 Hz at any position, including the centre position.</p>															

Parameter	Function	Range [Default]	Description / Notes																																													
P025 •	Analogue output	0 – 105 [0]	Display selection: 0 – 20 mA 4 – 20 mA 0 100 Output frequency 1 101 Frequency setpoint (i.e. speed at which inverter is set to run) 2 102 Motor current 3 103 DC-link voltage 4 104 Motor torque 5 105 Motor RPM																																													
P031 •	Jog frequency right (Hz)	0 – 650.00 [5.00]	Jogging is used to advance the motor by small amounts. It is usually controlled with a non-latching switch on one of the digital inputs (P051 to P055). If jog right is enabled (DINn = 7), this parameter controls the frequency at which the inverter will run when the switch is closed. Unlike other setpoints, it can be set lower than the minimum frequency.																																													
P032 •	Jog frequency left (Hz)	0 – 650.00 [5.00]	If jog left is enabled (DINn = 8), this parameter controls the frequency at which the inverter will run when the switch is closed. Unlike other setpoints, it can be set lower than the minimum frequency.																																													
P033 •	Jog ramp up time (seconds)	0 – 650.0 [10.0]	This is the time taken to accelerate from 0 Hz to maximum frequency (P013) for jog functions. It is <u>not</u> the time taken to accelerate from 0 Hz to the jog frequency.																																													
P034 •	Jog ramp down time (seconds)	0 – 650.0 [10.0]	This is the time taken to decelerate from maximum frequency (P013) to 0 Hz for jog functions. It is <u>not</u> the time taken to decelerate from the jog frequency to 0 Hz.																																													
P041 •	1st fixed frequency (Hz)	0 – 650.00 [5.00]	Valid if digital operation is selected and P055 = 6.																																													
P042 •	2nd fixed frequency (Hz)	0 – 650.00 [10.00]	Valid if digital operation is selected and P054 = 6.																																													
P043 •	3rd fixed frequency (Hz)	0 – 650.00 [20.00]	Valid if digital operation is selected and P053 = 6.																																													
P044 •	4th fixed frequency (Hz)	0 – 650.00 [40.00]	Valid if digital operation is selected and P052 = 6.																																													
P045	Inversion fixed setpoints for fixed frequencies 1 – 4	0 – 7 [0]	Sets the direction of rotation for the fixed frequency: <table border="1" data-bbox="870 1422 1402 1775"> <thead> <tr> <th></th> <th>FF 1</th> <th>FF 2</th> <th>FF 3</th> <th>FF 4</th> </tr> </thead> <tbody> <tr> <td>P045 = 0</td> <td>⇒</td> <td>⇒</td> <td>⇒</td> <td>⇒</td> </tr> <tr> <td>P045 = 1</td> <td>⇐</td> <td>⇒</td> <td>⇒</td> <td>⇒</td> </tr> <tr> <td>P045 = 2</td> <td>⇒</td> <td>⇐</td> <td>⇒</td> <td>⇒</td> </tr> <tr> <td>P045 = 3</td> <td>⇒</td> <td>⇒</td> <td>⇐</td> <td>⇒</td> </tr> <tr> <td>P045 = 4</td> <td>⇒</td> <td>⇒</td> <td>⇒</td> <td>⇐</td> </tr> <tr> <td>P045 = 5</td> <td>⇐</td> <td>⇐</td> <td>⇒</td> <td>⇒</td> </tr> <tr> <td>P045 = 6</td> <td>⇐</td> <td>⇐</td> <td>⇐</td> <td>⇒</td> </tr> <tr> <td>P045 = 7</td> <td>⇐</td> <td>⇐</td> <td>⇐</td> <td>⇐</td> </tr> </tbody> </table> ⇒ Fixed setpoints not inverted ⇐ Fixed setpoints inverted		FF 1	FF 2	FF 3	FF 4	P045 = 0	⇒	⇒	⇒	⇒	P045 = 1	⇐	⇒	⇒	⇒	P045 = 2	⇒	⇐	⇒	⇒	P045 = 3	⇒	⇒	⇐	⇒	P045 = 4	⇒	⇒	⇒	⇐	P045 = 5	⇐	⇐	⇒	⇒	P045 = 6	⇐	⇐	⇐	⇒	P045 = 7	⇐	⇐	⇐	⇐
	FF 1	FF 2	FF 3	FF 4																																												
P045 = 0	⇒	⇒	⇒	⇒																																												
P045 = 1	⇐	⇒	⇒	⇒																																												
P045 = 2	⇒	⇐	⇒	⇒																																												
P045 = 3	⇒	⇒	⇐	⇒																																												
P045 = 4	⇒	⇒	⇒	⇐																																												
P045 = 5	⇐	⇐	⇒	⇒																																												
P045 = 6	⇐	⇐	⇐	⇒																																												
P045 = 7	⇐	⇐	⇐	⇐																																												
P046 •	5th fixed frequency (Hz)	0 – 650.00 [0.00]	Valid if digital operation is selected and P053 or P054 or P055 = 17.																																													
P047 •	6th fixed frequency (Hz)	0 – 650.00 [0.00]	Valid if digital operation is selected and P053 or P054 or P055 = 17.																																													
P048 •	7th fixed frequency (Hz)	0 – 650.00 [0.00]	Valid if digital operation is selected and P053 or P054 or P055 = 17.																																													
P049 •	8th fixed frequency (Hz)	0 – 650.00 [0.00]	Valid if digital operation is selected and P053 or P054 or P055 = 17.																																													

Parameter	Function	Range [Default]	Description / Notes
-----------	----------	-----------------	---------------------

P050 Inversion fixed setpoints for fixed frequencies 5 – 8 0 – 7 [0] Sets the direction of rotation for the fixed frequency:

	FF 5	FF 6	FF 7	FF 8
P050 = 0	⇒	⇒	⇒	⇒
P050 = 1	⇐	⇒	⇒	⇒
P050 = 2	⇒	⇐	⇒	⇒
P050 = 3	⇒	⇒	⇐	⇒
P050 = 4	⇒	⇒	⇒	⇐
P050 = 5	⇐	⇐	⇒	⇒
P050 = 6	⇐	⇐	⇐	⇒
P050 = 7	⇐	⇐	⇐	⇐

⇒ Fixed setpoints not inverted
⇐ Fixed setpoints inverted

Parameter	Function	Range [Default]	Value	Function of P051 to P055	Function, low state	Function, high state
P051	Selection control function, DIN1 (terminal 8)	0 – 17 [1]	0	Input disabled	–	–
P052	Selection control function, DIN2 (terminal 9), fixed frequency 4	0 – 17 [2]	1	ON right	Off	On right
P053	Selection control function, DIN3 (terminal 10), fixed frequency 3. If set to 17, this enables the most significant bit of the 3-bit BCD (see table).	0 – 17 [6]	2	ON left	Off	On left
P054	Selection control function, DIN4 (terminal 11), fixed frequency 2. If set to 17, this enables the middle bit of the 3-bit BCD (see table).	0 – 17 [6]	3	Reverse	Normal	Reverse
P055	Selection control function, DIN5 (terminal 12), fixed frequency 1. If set to 17, this enables the least significant bit of the 3-bit BCD (see table).	0 – 17 [6]	4	OFF2	OFF2	On
			5	OFF3	OFF3	On
			6	Fixed frequencies	Off	On
			7	Jog right	Off	Jog right
			8	Jog left	Off	Jog left
			9	Remote operation	Local	Remote
			10	Fault code reset	Off	Reset on rising edge
			11	Increase frequency	Off	Increase
			12	Decrease frequency	Off	Decrease
			13	Disable analogue input (setpoint is 0.0 Hz)	Analogue on	Analogue disabled
			14	Disable 'P' button	'P' enabled	'P' disabled
			15	Enable dc brake	Off	Brake on
			16	Use jog ramp times instead of normal ramp times	Normal	Jog ramp times
			17	Binary fixed frequency control (fixed frequencies 5 – 8)	Off	On

Binary Coded Fixed Frequency Mapping

	DIN3 (P053)	DIN4 (P054)	DIN5 (P055)
FF5 (P046)	0	0	0
FF6 (P047)	0	0	1
FF7 (P048)	0	1	0
FF8 (P049)	0	1	1
FF1 (P041)	1	0	0
FF2 (P042)	1	0	1
FF3 (P043)	1	1	0
FF4 (P044)	1	1	1

Note: If P051 or P052 = 6 while P053 or P054 or P055 = 17 then the setpoints are added.

For detailed information regarding binary coded fixed frequency mapping, please contact your local Siemens sales office.

Parameter	Function	Range [Default]	Description / Notes																																							
P056	Digital input debounce time	0 – 2 [0]	<p>0 = 12.5 ms 1 = 7.5 ms 2 = 2.5 ms</p> <p>The response time to a digital input = (debounce time + 7.5 ms).</p>																																							
P061	Selection relay output RL1	0 – 11 [6]	<table border="1"> <thead> <tr> <th>Value</th> <th>Relay function</th> <th>Active</th> </tr> </thead> <tbody> <tr> <td>0</td> <td>No function assigned (relay not active)</td> <td>Low</td> </tr> <tr> <td>1</td> <td>Inverter is running</td> <td>High</td> </tr> <tr> <td>2</td> <td>Inverter frequency 0.0 Hz</td> <td>Low</td> </tr> <tr> <td>3</td> <td>Motor running direction right</td> <td>High</td> </tr> <tr> <td>4</td> <td>Brake on (see parameters P063/P064)</td> <td>Low</td> </tr> <tr> <td>5</td> <td>Inverter frequency less than or equal to minimum frequency</td> <td>Low</td> </tr> <tr> <td>6</td> <td>Fault indication</td> <td>Low</td> </tr> <tr> <td>7</td> <td>Inverter frequency greater than or equal to setpoint</td> <td>High</td> </tr> <tr> <td>8</td> <td>Warning</td> <td>Low</td> </tr> <tr> <td>9</td> <td>Output current greater than or equal to P065</td> <td>High</td> </tr> <tr> <td>10</td> <td>Motor current limit (warning)</td> <td>Low</td> </tr> <tr> <td>11</td> <td>Motor over temperature (warning)</td> <td>Low</td> </tr> </tbody> </table> <p>Note: 'Active low' = relay OFF. 'Active high' = relay ON.</p>	Value	Relay function	Active	0	No function assigned (relay not active)	Low	1	Inverter is running	High	2	Inverter frequency 0.0 Hz	Low	3	Motor running direction right	High	4	Brake on (see parameters P063/P064)	Low	5	Inverter frequency less than or equal to minimum frequency	Low	6	Fault indication	Low	7	Inverter frequency greater than or equal to setpoint	High	8	Warning	Low	9	Output current greater than or equal to P065	High	10	Motor current limit (warning)	Low	11	Motor over temperature (warning)	Low
Value	Relay function	Active																																								
0	No function assigned (relay not active)	Low																																								
1	Inverter is running	High																																								
2	Inverter frequency 0.0 Hz	Low																																								
3	Motor running direction right	High																																								
4	Brake on (see parameters P063/P064)	Low																																								
5	Inverter frequency less than or equal to minimum frequency	Low																																								
6	Fault indication	Low																																								
7	Inverter frequency greater than or equal to setpoint	High																																								
8	Warning	Low																																								
9	Output current greater than or equal to P065	High																																								
10	Motor current limit (warning)	Low																																								
11	Motor over temperature (warning)	Low																																								
P062	Selection relay output RL2	0 – 11 [8]	Sets the relay function, output RL2 (terminals 19/20) (refer to the table in P061).																																							
P063	External brake release delay (seconds)	0 – 20.0 [1.0]	Only effective if the relay output is set to control an external brake (P061 = 4). In this case when the inverter is switched on, it will run at the minimum frequency for the time set by this parameter before releasing the brake control relay and ramping up (see illustration in P064).																																							
P064	External brake stopping time (seconds)	0 – 20.0 [1.0]	As P063, only effective if the relay output is set to control an external brake. This defines the period for which the inverter continues to run at the minimum frequency after ramping down and while the external brake is applied.																																							

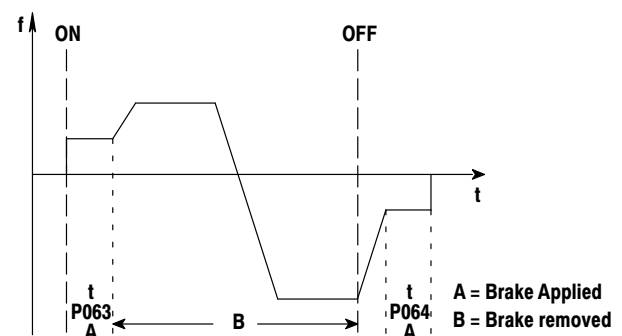

- Notes:**
- (1) Settings for P063 and P064 should be slightly longer than the actual time taken for the external brake to apply and release respectively.
 - (2) Setting P063 or P064 to too high a value, especially with P012 set to a high value, can cause an overcurrent warning or trip as the inverter attempts to move a locked motor shaft.

Parameter	Function	Range [Default]	Description / Notes
P065	Current threshold for relay (A)	0 – 99.9 [1.0]	This parameter is used in conjunction with option 9 for the relay output (P061). The relay switches on when the motor current is greater than the value of P065 and switches off when the current falls to 90% of the value of P065 (hysteresis).
P071 •	Slip compensation (%)	0 – 200 [0]	The inverter can estimate the amount of slip in an asynchronous motor at varying loads and increase its output frequency to compensate. This parameter 'fine tunes' the compensation for different motors in the range 0 – 200% of the inverter's nominal estimate. WARNING: This parameter must be set to zero when using synchronous motors or motors that are connected in parallel.
P072 •	Slip limit (%)	0 – 500 [250]	This limits the slip of the motor to prevent 'pull-out' (stalling), which can occur if slip is allowed to increase indefinitely. When the slip limit is reached, the inverter reduces the frequency until the level of slip is acceptable.
P073 •	DC injection braking (%)	0 – 250 [0]	This stops the motor by applying a dc current. This causes heat to be generated in the motor rather than the inverter and holds the shaft stationary until the end of the braking period. Braking is effective for the period of time set by P003. This function is disabled if P061 = 4 (brake relay). WARNING: Frequent use of long periods of dc injection braking can cause the motor to overheat.
P074 •	Motor derating curve as temperature protection	0 – 3 [0]	Self-cooling fan ventilated motors tend to overheat at low speeds. This is because the current (and therefore the heat) generated in the motor is the same, but the rate of heat dissipation from the motor is only about 25% of normal when the fan is not running. It may be necessary, therefore, to derate a self-cooled motor at low speeds using this parameter. The following derating curves are available: <div style="text-align: center;"> <p>P074 = 0 P074 = 1 P074 = 3 P074 = 2</p> <p>100% I_N 50% I_N</p> <p>50% F_N 100% F_N 150% F_N</p> <p>I_N = Nominal motor current (P083) F_N = Nominal motor frequency (P081)</p> </div>
P075 •	Braking resistance (Ω)	0/50 – 250 [0]	An external braking resistor can be used to 'dump' the power generated by the motor, thus giving greatly improved braking capabilities. It MUST NOT be less than 50 Ω or the inverter will be damaged. The 200 Ω purpose-made resistor (available as an accessory) is recommended. Take care if an alternative resistor is to be used as the pulsed voltage applied by the inverter can destroy ordinary resistors. Set P075 = 0 if an external braking resistor is not required.

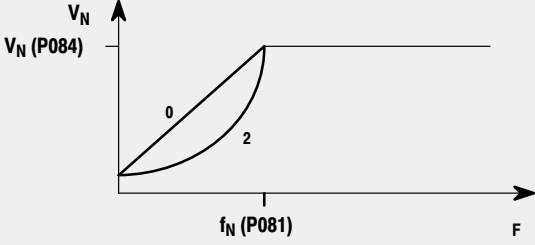
Parameter	Function	Range [Default]	Description / Notes
P076 •	Pulse frequency	0 – 10 [0]	<p>Sets the pulse frequency (from 2.44 to 16 kHz) and the PWM mode. If silent operation is not absolutely necessary, the losses in the inverter and motor as well as the RFI emission can be reduced by selecting lower pulse frequencies.</p> <p>Previously used modulation modes 1 and 2 are now combined and selected automatically by the inverter. Mode 3 randomises the pulse frequency to avoid resonance and can be used to reduce noise in the motor.</p> <p>0/1 = 16 kHz 8 = 8 – 16 kHz modulation mode 3 2/3 = 8 kHz 9 = 4 – 8 kHz modulation mode 3 4/5 = 4 kHz 10 = 2.44 – 4 kHz modulation mode 3 6/7 = 2.44 kHz</p> <p>Note: When P076 = 0/1, the display of the current at frequencies below 10 Hz is less accurate.</p>
P077	Control mode	0 – 2 [1]	<p>Controls the relationship between the speed of the motor and the voltage supplied by the inverter. One of three modes can be selected:</p> <p>0 = Linear voltage/frequency Use this curve for synchronous motors or motors connected in parallel.</p> <p>1 = Flux Current Control (FCC) In this mode the inverter makes real-time calculations of the required voltage by modelling the behaviour of the motor. This allows it to adjust the motor for full flux in all conditions.</p> <p>2 = Quadratic voltage/frequency relationship This is suitable for pumps and fans.</p> 
P078 •	Continuous boost (%)	0 – 250 [100]	<p>Operates continuously over the whole frequency range. For some applications it is necessary to increase low frequency torque. This parameter sets the start-up current at 0 Hz to adjust the available torque for low frequency operation. Range 0 – 250% of the motor current rating.</p> <p>WARNING: If P078 is set too high, overheating of the motor can result.</p>
P079 •	Starting boost (%)	0 – 250 [0]	<p>For drives which require a high initial starting torque, it is possible to set an extra voltage increase by boosting the starting current by 0 – 250% of the nominal motor current. This increase is only effective during initial start up and until the frequency setpoint is reached.</p> <p>Note: This increase is in addition to P078.</p>
P081	Nominal frequency for motor (Hz)	0 – 650.00 [50.00]	<p>These parameters must be set for the motor used. Read the specifications on the motor's rating plate (see Figure 12 in section 4.1).</p> <p>Note: The inverter's default settings vary according to the power rating.</p>
P082	Nominal speed for motor (RPM)	0 – 9999 [☆☆☆]	
P083	Nominal current for motor (A)	0.1 – 99.9 [☆☆☆]	
P084	Nominal voltage for motor (V)	0 – 1000 [☆☆☆]	
P085	Nominal power for motor (kW)	0 – 50.0 [☆☆☆]	

Parameter	Function	Range [Default]	Description / Notes
P086 •	Motor current limit (%)	0 – 250 [150]	With this parameter the motor current can be limited and overheating of the motor prevented. If the set value is exceeded, the output frequency is reduced until the current falls below this limit. During this process the display flashes as a warning indication.
P087 •	Motor PTC enable	0 – 1 [0]	0 = Disabled 1 = External PTC enabled Note: If P087 = 1 and the PTC input goes high then the inverter will trip (fault code F004 displayed). The relay will not operate unless it is set to a general fault (P061 = 6). If P061 = 11 then the relay operates as a warning if either the internal PTC gets hot (indicating high heatsink temperature) or if P074 is activated. Warning code 005 is written to P931 and the display flashes. Note that if the internal PTC gets too hot, the inverter will trip and F005 will be displayed.
P088	Automatic calibration	0 – 1 [0]	The stator resistance is used in the inverter's current monitoring calculations. Set this parameter to '1' to calibrate for stator resistance. The next time the inverter is set to run, it performs an automatic measurement of stator resistance, stores it in P089 and then resets P088 to '0'.
P089 •	Stator resistance (Ω)	0.01 – 100.00 [☆☆☆☆]	Can be used instead of P088 to set the stator resistance manually. The value entered should be the resistance between any two phases.
P091 •	Slave address	0 – 30 [0]	Up to 31 inverters can be connected via the serial link and controlled by a computer or PLC using the USS protocol. This parameter sets a unique address for the inverter.
P092 •	Baud rate	3 – 7 [6]	Sets the baud rate of the RS485 serial interface (USS protocol): 3 = 1200 baud 4 = 2400 baud 5 = 4800 baud 6 = 9600 baud 7 = 19200 baud Note: Some RS232 to RS485 converters are not capable of baud rates higher than 4800.
P093 •	Timeout (seconds)	0 – 240 [0]	This is the maximum permissible period between two incoming data telegrams. In applications where the inverter is usually controlled or monitored constantly via the serial link, this feature is used to turn off the inverter in the event of a communications failure. Timing starts after a valid data telegram has been received and if a further data telegram is not received within the specified time period, the inverter will trip and display fault code F008. Setting the value to zero switches off the control.
P094 •	Serial link nominal system setpoint (Hz)	0 – 650.00 [50.00]	Setpoints are transmitted to the inverter via the serial link as percentages. The value entered in this parameter represents 100%. Thus, if P094 = 60 and the inverter receives the instruction to run at 25%, the output frequency will be 15 Hz.
P095	USS compatibility	0 – 2 [0]	0 = Compatible with 0.1 Hz resolution 1 = Enable 0.01 Hz resolution 2 = PZD is not scaled but represents the actual frequency value to a resolution of 0.01 Hz.
P101 •	Operation for Europe or USA	0 – 1 [0]	This sets the inverter for European or USA supply and motor frequency: 0 = Europe (50 Hz) 1 = USA (60 Hz)
P111	Power rating (kW/hp)	0.0 – 50.00 [☆☆☆☆]	Read-only parameter that indicates the power rating of the inverter in kW. e.g. 0.55 = 550 W Note: If P101 = 1 then the rating is displayed in hp.

Parameter	Function	Range [Default]	Description / Notes
P121	Enable/disable RUN button	0 – 1 [1]	0 = RUN button disabled 1 = RUN button enabled (effective if P007 = 1)
P122	Enable/disable FORWARD/REVERSE button	0 – 1 [1]	0 = FORWARD/REVERSE button disabled (effective if P007 = 0) 1 = FORWARD/REVERSE button enabled
P123	Enable/disable JOG button	0 – 1 [1]	0 = JOG button disabled (effective if P007 = 0) 1 = JOG button enabled
P124	Enable/disable Δ button	0 – 1 [1]	0 = Δ button disabled (effective if P007 = 0) 1 = Δ button enabled Note: If this parameter is set to 0, only the facility to increase the frequency is affected.
P131	Frequency setpoint (Hz)	0.00 – 650.00 [-]	Read-only parameters. These are copies of the values stored in P001 but can be accessed directly via the serial link.
P132	Motor current (A)	0.0 – 99.9 [-]	
P133	Motor torque (%)	0 – 250 [-]	
P134	DC link voltage (V)	0 – 1000 [-]	
P135	Motor RPM	0 – 9999 [-]	
P910 •	Local/Remote mode	0 – 3 [0]	Sets the inverter for local control or remote control over the serial link: 0 = Local control 1 = Remote control (and setting of parameter values) 2 = Local control (but remote control of frequency) 3 = Remote control (but local control of frequency) Note: When operating the inverter via remote control (P910 = 1 or 3), the analogue input remains active when P006 = 1
P922	Software version	0 – 9999 [-]	Contains the software version number and cannot be changed.
P923 •	Equipment system number	0 – 255 [0]	You can use this parameter to allocate a unique reference number to the inverter. It has no operational effect.
P930	Most recent fault code	0 – 9999 [-]	The last recorded fault code (<i>see section 6</i>) is stored in this parameter. It is cleared when the inverter is reset.
P931	Most recent warning type	0 – 9999 [-]	The last recorded warning is stored in this parameter until power is removed from the inverter: 002 = Current limit active 003 = Voltage limit active 004 = Slip limit exceeded 005 = Motor overtemperature
P944	Reset to factory default settings	0 – 1 [0]	Set to '1' and then press P to reset all parameters except P101 to the factory default settings.

6. FAULT CODES

In the event of a failure, the inverter switches off and an error code appears on the display. The last error that occurred is stored in parameter P930. e.g. '0004' indicates that the last error was F004.

Fault Code	Cause	Corrective Action
F001	Overvoltage	Check whether supply voltage is within the limits indicated on the rating plate. Increase the ramp down time (P003) or apply braking resistor (option). Check whether the required braking power is within the specified limits.
F002	Overcurrent	Check whether the motor power corresponds to the inverter power. Check motor lead and motor for short-circuits and earth faults. Check whether the motor parameters (P081 – P086) correspond with the motor being used. Increase the ramp-up time (P002). Reduce the boost set in P078 and P079. Check whether the motor is obstructed or overloaded.
F003	Overload	Check whether the motor is overloaded. Increase the maximum motor frequency if a motor with high slip is used.
F004	Overheating of motor (monitoring with PTC)	Check whether the motor is overloaded. Check the connections to the PTC. Check that P087 has not been set to '1' without a PTC being connected.
F005	Inverter overtemperature	Check that the ambient temperature is not too high. Check that the air inlet and outlet are not obstructed.
F006	Mains phase missing (3-phase units only)	Check the mains supply and rectify.
F008	USS protocol timeout	Check the serial interface. Check the settings of the bus master and P091 – P093. Check whether the timeout interval is too short (P093).
F009	Undervoltage	Check the supply voltage.
F010	Initialisation fault	Check the entire parameter set. Set P009 to '0000' before power down.
F011	Internal interface fault	Switch off power and switch on again.
F013	Programme fault	Switch off power and switch on again.
F106	Parameter fault P006	Parameterise fixed frequency(ies) and/or motor potentiometer on the digital inputs.
F112	Parameter fault P012	Set parameter P012 < P013.
F151 – F154	Digital input parameter fault	Change the settings of digital inputs P052 to P055.

When the fault has been corrected the inverter can be reset. To do this press button **P** twice (once to display P000 and the second time to reset the fault), or erase the fault via a binary input (*see parameters P051 – P055 in section 5*).

7. SPECIFICATIONS AND SUPPLEMENTARY INFORMATION

7.1 Specifications

Single Phase MICRO MASTER Inverters							
Inverter model	MM25	MM37	MM55	MM75	MM110	MM150	MM220
Input voltage range	1 AC 230 V +/-15%						
Motor output rating ¹	250 W	370 W	550 W	750 W	1.1 kW	1.5 kW	2.2 kW
Continuous output	660 VA	880 VA	1.14 kVA	1.5 kVA	2.1 kVA	2.8 kVA	4.0 kVA
Output current (nom.)	1.5 A	2.0 A	2.6 A	3.4 A	4.8 A	6.4 A	9.0 A
Output current (max. continuous)	1.6 A	2.3 A	3.3 A	3.9 A	5.5 A	7.1 A	10.4 A
Input current	3.0 A	3.8 A	5.5 A	6.5 A	14.0 A	18.0 A	20.0 A
Recommended mains fuse	10 A			16 A	20 A		25 A
Recommended lead cross-section (min.)	Input	1.0 mm ²		1.5 mm ²	2.5 mm ²		
	Output	1.0 mm ²			1.5 mm ²		
Dimensions (mm) (w x h x d)	112 x 182 x 113				149 x 184 x 157		185 x 215 x 195
Weight	1.9 kg				2.6 kg		5.0 kg

230 V Three Phase MICRO MASTER Inverters								
Inverter model	MM25/2	MM37/2	MM55/2	MM75/2	MM110/2	MM150/2	MM220/2	MM300/2
Input voltage range	3 AC 230 V +/-15%							
Motor output rating ¹	250 W	370 W	550 W	750 W	1.1 kW	1.5 kW	2.2 kW	3.0 kW
Continuous output	660 VA	880 VA	1.14 kVA	1.5 kVA	2.1 kVA	2.8 kVA	4.0 kVA	5.2 kVA
Output current (nom.)	1.5 A	2.0 A	2.6 A	3.4 A	4.8 A	6.4 A	9.0 A	11.8 A
Output current (max. continuous)	1.6 A	2.3 A	3.3 A	3.9 A	5.5 A	7.1 A	10.4 A	12.9 A
Input current	2.1 A	3.0 A	4.2 A	5.0 A	7.0 A	9.5 A	12.0 A	14.5 A
Recommended mains fuse	10 A			16 A		20 A		
Recommended lead cross-section (min.)	Input	1.0 mm ²		1.5 mm ²		2.5 mm ²		
	Output	1.0 mm ²			1.5 mm ²		2.5 mm ²	
Dimensions (mm) (w x h x d)	112 x 182 x 113				149 x 184 x 142		185 x 215 x 162	
Weight	1.8 kg				2.4 kg		4.5 kg	

400 V – 500 V Three Phase MICRO MASTER Inverters					
Inverter model	MM150/3	MM220/3	MM300/3	MM400/3	MM550/3
Input voltage range	3 AC 400 V – 500 V +/-10%				
Motor output rating ¹	1.5 kW	2.2 kW	3.0 kW	4.0 kW	5.5 kW
Continuous output	2.8 kVA	4.0 kVA	5.2 kVA	7.0 kVA	9.0 kVA
Output current (nom.)	3.7 A	5.2 A	6.8 A	9.2 A	11.8 A
Output current (max. continuous)	4.0 A	5.9 A	7.7 A	10.2 A	13.2 A
Input current	5.5 A	7.5 A	10.0 A	12.5 A	16.0 A
Recommended mains fuse	10 A	16 A		20 A	
Recommended lead cross-section (min.)	Input	1.0 mm ²	1.5 mm ²		2.5 mm ²
	Output	1.0 mm ²			1.5 mm ²
Dimensions (mm) (w x h x d)	185 x 215 x 195				
Weight	5.0 kg				

¹ Siemens 4 pole-motor, 1LA5 series or equivalent.

230 V Three Phase MIDI MASTER Inverters												
Inverter model	MD550/2		MD750/2		MD1100/2		MD1500/2		MD1850/2		MD2200/2	
Constant torque (CT) Variable torque (VT)	CT	VT	CT	VT	CT	VT	CT	VT	CT	VT	CT	VT
Input voltage range	3 AC 230 V +/-15%											
Motor output rating ¹ (kW)	5.5	7.5	7.5	11.0	11.0	15.0	15.0	18.5	18.5	22.0	22.0	n/a
Continuous output (kVA)	9.1	10.9	12.7	15.4	17.6	20.7	21.4	25.5	25.9	29.7	30.7	n/a
Output current (nom.) (A)	20.4	-	27.4	-	38.6	-	52.0	-	64.1	-	74.5	-
Output current (max. continuous) (A)	22.9	27.4	31.9	38.6	44.3	52.0	53.7	64.1	65.0	74.5	77.1	n/a
Input current (A)	32		45		61		75		87		90	
Recommended mains fuse (A)	32		50		63		80		100			
Recommended lead cross-section (mm ²)	Input (min.)		10		16		25		35			
	Output (min.)		6		10		16				25	
Dimensions (mm) (w x h x d)	275 x 450 x 200			275 x 550 x 202				275 x 650 x 278				
Weight (kg)	20.5		24.0		25.0		28.0		30.0		32.0	

400 V – 500 V Three Phase MIDI MASTER Inverters														
Inverter model	MD750/3		MD1100/3		MD1500/3		MD1850/3		MD2200/3		MD3000/3		MD3700/3	
Constant torque (CT) Variable torque (VT)	CT	VT	CT	VT	CT	VT	CT	VT	CT	VT	CT	VT	CT	VT
Input voltage range	3 AC 380 V – 500 V +/-10%													
Motor output rating ¹ (kW)	7.5	11.0	11.0	15.0	15.0	18.5	18.5	22.0	22.0	30.0	30.0	37.0	37.0	n/a
Continuous output (kVA)	12.7	17.7	17.7	21.5	21.5	26.0	26.0	30.8	30.8	40.8	40.8	49.9	49.9	n/a
Output current (nom.) @ 400 V (A)	17.5	-	24.5	-	29.5	-	35.5	-	42.5	-	55.0	-	68.0	-
Output current (max. continuous) @ 400 V (A)	18.4	24.5	25.6	27.5	31.0	35.5	37.5	42.5	44.5	55.0	59.0	68.0	72.0	n/a
Input current (A)	30		32		41		49		64		79		96	
Recommended mains fuse (A)	32		50		80		100							
Recommended lead cross-section (mm ²)	Input (min.)		10		25		35							
	Output (min.)		6		10		16		25					
Dimensions (mm) (w x h x d)	275 x 450 x 200			275 x 550 x 202				275 x 650 x 278						
Weight (kg)	19.5		20.5		24.0		25.0		28.0		30.0		32.0	

575 V Three Phase MIDI MASTER Inverters														
Inverter model	MD750/4		MD1100/4		MD1500/4		MD1850/4		MD2200/4		MD3000/4		MD3700/4	
Constant torque (CT) Variable torque (VT)	CT	VT	CT	VT	CT	VT	CT	VT	CT	VT	CT	VT	CT	VT
Input voltage range	3 AC 575 V +/-10%													
Motor output rating ¹ (kW)	7.5	11.0	11.0	15.0	15.0	18.5	18.5	22.0	22.0	30.0	30.0	37.0	37.0	45.0
Continuous output (kVA)	12.0	14.6	16.8	19.7	20.3	24.4	24.6	28.3	29.3	37.8	38.8	46.7	47.4	55.2
Output current (nom.) (A)	10.4	-	14.7	-	19.8	-	24.5	-	28.4	-	38.0	-	46.9	-
Output current (max. continuous) (A)	12.1	14.7	16.9	19.8	20.4	24.5	24.7	28.4	29.4	38.0	39.0	46.9	47.6	55.5
Input current (A)	18		24		29		34		45		55		65	
Recommended mains fuse (A)	25		32		40		50		63		80			
Recommended lead cross-section (mm ²)	Input (min.)		6		10		16		25					
	Output (min.)		4		6		10		16					
Dimensions (mm) (w x h x d)	275 x 450 x 200			275 x 550 x 202				275 x 650 x 278						
Weight (kg)	19.5		20.5		24.0		25.0		28.0		30.0		32.0	

¹ Siemens 4 pole-motor, 1LA5 series or equivalent.

MICRO MASTER and MIDI MASTER

Operating Instructions

Input frequency:	47 Hz to 63 Hz
Power factor:	$\lambda \geq 0.7$
Output frequency range:	0 Hz to 650 Hz
Resolution:	0.01 Hz
Overload capability:	150% for 60s
Protection against:	Inverter overtemperature Motor overtemperature Overvoltage and undervoltage
Additional protection:	Against short-circuits and earth/ground faults pull-out protection, automatic compensation for supply fluctuations
Operating mode:	4 quadrants possible
Regulation and control:	FCC (Flux Current Control) voltage/frequency curve
Analogue setpoint:	0 – 10 V/2 – 10 V (recommended potentiometer 4.7 k Ω) 0 – 20 mA/4 – 20 mA
Analogue setpoint resolution:	10-bit
Setpoint stability:	Analogue < 1%
Setpoint stability:	Digital < 0.02%
Motor temperature monitoring:	PTC input, I ² t control
Ramp times:	0 – 650 s
Control outputs:	2 relays 240 V AC / 1 A; 24 V DC / 2 A WARNING: External inductive loads must be suppressed in an appropriate manner (see section 2.1 (5)).
Interface:	RS485
Inverter efficiency:	97%
Ambient temperature:	0°C to +40°C (up to 50°C without cover)
Max. heatsink temperature:	65°C
Ventilation:	Convection cooling or fan cooling, depending on power rating
Humidity:	90% non-condensing
Installation height above sea level:	1000 m
Degree of protection:	NEMA1 (IP21) (National Electrical Manufacturers' Association)

7.2 Options / Accessories

Braking resistor (MICRO MASTER)
Braking unit (MIDI MASTER)
RFI suppression filter
Enhanced operator panel

*Please contact your local
Siemens sales office for
further details*

7.3 Application Example

Setup procedure for a simple application

Motor:	220 V 1.5 kW output power
Application requirements:	Setpoint adjustable via potentiometer 0 – 50 Hz Ramp up from 0 to 50 Hz in 15 seconds Ramp down from 50 to 0 Hz in 20 seconds
Inverter used:	MM150 (6SE3116–8BB40)
Settings:	P009 = 2 (all parameters can be altered) P081 – P085 = values given on motor rating plate P006 = 1 (analogue input) P002 = 15 (ramp up time) P003 = 20 (ramp down time)

This application is now to be modified as follows:

Operation of motor up to 75 Hz
(voltage/frequency curve is linear up to 50 Hz).
Motor potentiometer setpoint in addition to
analogue setpoint.
Use of analogue setpoint at maximum 10 Hz.

i.e.

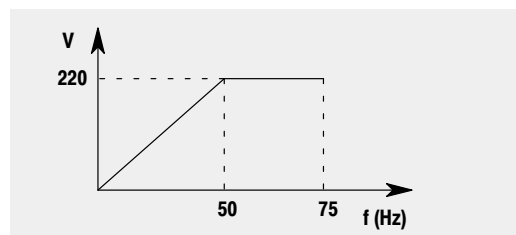

Parameter adjustments:	P009 = 2 (all parameters can be altered) P013 = 75 (maximum motor frequency in Hz) P006 = 2 (setpoint via motor potentiometer or fixed setpoint) P024 = 1 (analogue setpoint is added) P022 = 10 maximum analogue setpoint at 10 V = 10 Hz
------------------------	--

7.4 Technical Terms

Baud	A unit of measure for the speed of data transmission named after Jean Baudot. One Baud corresponds to one bit per second (bps).
CPU	Abbreviation for C entral P rocessing U nit of a computer.
FCC	F lux C urrent C ontrol for optimum motor efficiency and high dynamic range.
4 Q Control	Four quadrant control of a motor, driving and braking in both directions.
Interface	The means by which a micro-computer can be connected to other components.
NEMA	Abbreviation for N ational E lectrical M anufacturers' A ssociation.
PLC	Abbreviation for P rogrammable L ogic C ontroller
PTC	Abbreviation for P ositive T emperature C oefficient. The resistance of which increases if the temperature rises.
PWM	P ulse W idth M odulation.
RS485	R ecommended S tandard. Recommended standard for computer interfaces.
Status Information	Identification of the status in data processing.
USS Protocol	U niver S al S erial interface protocol

7.5 Parameter Summary List

- = Parameter can be changed during operation.
- ☆☆☆ = Value depends on the rating of the inverter.

Parameter	Function	Range [Default]	Parameter	Function	Range [Default]
P000	Operating display	-	P042 •	2nd fixed frequency (Hz)	0 – 650.00 [10.00]
P001 •	Display selection	0 – 6 [0]	P043 •	3rd fixed frequency (Hz)	0 – 650.00 [20.00]
P002 •	Ramp up time (seconds)	0 – 650.0 [10.0]	P044 •	4th fixed frequency (Hz)	0 – 650.00 [40.00]
P003 •	Ramp down time (seconds)	0 – 650.0 [10.0]	P045	Inversion fixed setpoints 1 – 4	0 – 7 [0]
P004 •	Smoothing (seconds)	0 – 40.0 [0.0]	P046 •	5th fixed frequency (Hz)	0 – 650.00 [0.00]
P005 •	Digital frequency setpoint (Hz)	0 – 650.00 [0.00]	P047 •	6th fixed frequency (Hz)	0 – 650.00 [0.00]
P006	Frequency setpoint type selection	0 – 2 [0]	P048 •	7th fixed frequency (Hz)	0 – 650.00 [0.00]
P007	Enable/disable front panel buttons	0 – 1 [1]	P049 •	8th fixed frequency (Hz)	0 – 650.00 [0.00]
P009 •	Parameter protection setting	0 – 3 [0]	P050	Inversion fixed setpoints 5 – 8	0 – 7 [0]
P011	Frequency setpoint memory	0 – 1 [0]	P051	Selection control function, DIN1 (terminal 8)	0 – 17 [1]
P012 •	Minimum motor frequency (Hz)	0 – 650.00 [0.00]	P052	Selection control function, DIN2 (terminal 9), fixed frequency 4	0 – 17 [2]
P013 •	Maximum motor frequency (Hz)	0 – 650.00 [50.00]	P053	Selection control function, DIN3 (terminal 10), fixed frequency 3	0 – 17 [6]
P014 •	Skip frequency (Hz)	0 – 650.00 [0.00]	P054	Selection control function, DIN4 (terminal 11), fixed frequency 2	0 – 17 [6]
P015 •	Automatic restart	0 – 1 [0]	P055	Selection control function, DIN5 (terminal 12), fixed frequency 1	0 – 17 [6]
P016 •	Start on the fly	0 – 2 [0]	P056	Digital input debounce time	0 – 2 [0]
P017	Smoothing type	0 – 1 [0]	P061	Selection relay output RL1	0 – 11 [6]
P018	Automatic restart after fault	0 – 1 [0]	P062	Selection relay output RL2	0 – 11 [8]
P021 •	Minimum analogue frequency (Hz)	0 – 650.00 [0.00]	P063	External brake release delay (seconds)	0 – 20.0 [1.0]
P022 •	Maximum analogue frequency (Hz)	0 – 650.00 [50.00]	P064	External brake stopping time (seconds)	0 – 20.0 [1.0]
P023 •	Analogue input type	0 – 2 [0]	P065	Current threshold for relay (A)	0 – 99.9 [1.0]
P024 •	Analogue setpoint addition	0 – 1 [0]	P071 •	Slip compensation (%)	0 – 200 [0]
P025 •	Analogue output	0 – 105 [0]	P072 •	Slip limit (%)	0 – 500 [250]
P031 •	Jog frequency right (Hz)	0 – 650.00 [5.00]	P073 •	DC injection braking (%)	0 – 250 [0]
P032 •	Jog frequency left (Hz)	0 – 650.00 [5.00]	P074 •	Motor derating curve as temperature protection	0 – 3 [0]
P033 •	Jog ramp up time (seconds)	0 – 650.0 [10.0]	P075 •	Braking resistance (Ω)	0/50 – 250 [0]
P034 •	Jog ramp down time (seconds)	0 – 650.0 [10.0]	P076 •	Pulse frequency	0 – 10 [0]
P041 •	1st fixed frequency (Hz)	0 – 650.00 [5.00]			

continued over

Parameter	Function	Range [Default]
P077	Control mode	0 – 2 [1]
P078 •	Continuous boost (%)	0 – 250 [100]
P079 •	Starting boost (%)	0 – 250 [0]
P081	Nominal frequency for motor (Hz)	0 – 650.00 [50.00]
P082	Nominal speed for motor (RPM)	0 – 9999 [☆☆☆]
P083	Nominal current for motor (A)	0.1 – 99.9 [☆☆☆]
P084	Nominal voltage for motor (V)	0 – 1000 [☆☆☆]
P085	Nominal power for motor (kW)	0 – 50.0 [☆☆☆]
P086 •	Motor current limit (%)	0 – 250 [150]
P087 •	Motor PTC enable	0 – 1 [0]
P088	Automatic calibration	0 – 1 [0]
P089 •	Stator resistance (Ω)	0.01 – 100.00 [☆☆☆]
P091 •	Slave address	0 – 30 [0]
P092 •	Baud rate	3 – 7 [6]
P093 •	Timeout (seconds)	0 – 240 [0]
P094 •	Serial link nominal system setpoint (Hz)	0 – 650.00 [50.00]
P095	USS compatibility	0 – 2 [0]

Parameter	Function	Range [Default]
P101 •	Operation for Europe or USA	0 – 1 [0]
P111	Power rating (kW/hp)	0.0 – 50.00 [☆☆☆]
P121	Enable/disable RUN button	0 – 1 [1]
P122	Enable/disable FORWARD/REVERSE button	0 – 1 [1]
P123	Enable/disable JOG button	0 – 1 [1]
P124	Enable/disable Δ button	0 – 1 [1]
P131	Frequency setpoint (Hz)	0.00 – 650.00 [-]
P132	Motor current (A)	0.0 – 99.9 [-]
P133	Motor torque (%)	0 – 250 [-]
P134	DC link voltage (V)	0 – 1000 [-]
P135	Motor RPM	0 – 9999 [-]
P910 •	Local/Remote mode	0 – 3 [0]
P922	Software version	0 – 9999 [-]
P923 •	Equipment system number	0 – 255 [0]
P930	Most recent fault code	0 – 9999 [-]
P931	Most recent warning type	0 – 9999 [-]
P944	Reset to factory default settings	0 – 1 [0]